

**This electronic collection of documents is provided
for the convenience of the user
and is Not a Certified Document –**

**The documents contained herein were originally issued
and sealed by the individuals whose names and license
numbers appear on each page, on the dates appearing
with their signature on that page.**

**This file or an individual page
shall not be considered a certified document.**

VERTICAL CURVE DATA -L-

(-)6.1071% (-)0.3105%
 PI = 14+80.00
 EL = 349.55'
 VC = 180'

VERTICAL CURVE DATA -L-

(-)0.3105% (+)2.6778%
 PI = 16+70.00
 EL = 348.96'
 VC = 100'

SPAN A

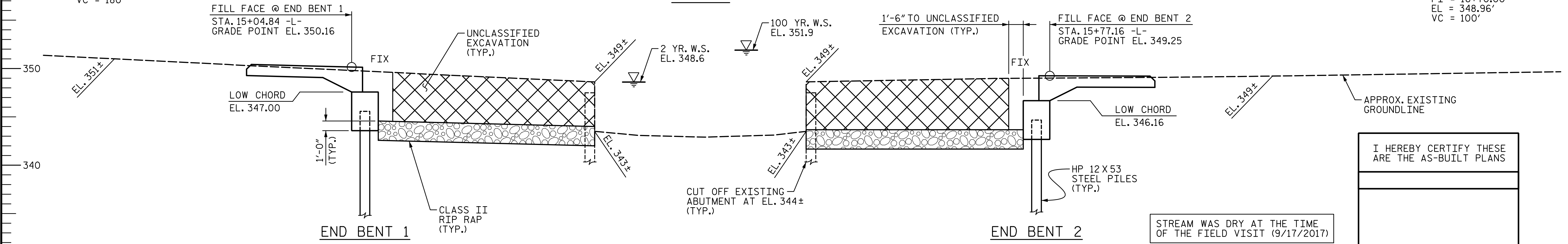

SECTION ALONG -L-
 (SECTION AT END BENTS TAKEN AT RIGHT ANGLES)

I HEREBY CERTIFY THESE ARE THE AS-BUILT PLANS

RESIDENT ENGINEER

STREAM WAS DRY AT THE TIME OF THE FIELD VISIT (9/17/2017)

HORIZONTAL CURVE DATA -L-

PI STA. = 16+65.63 -L-
 $\Delta = 20^\circ-38'-48.9\"$

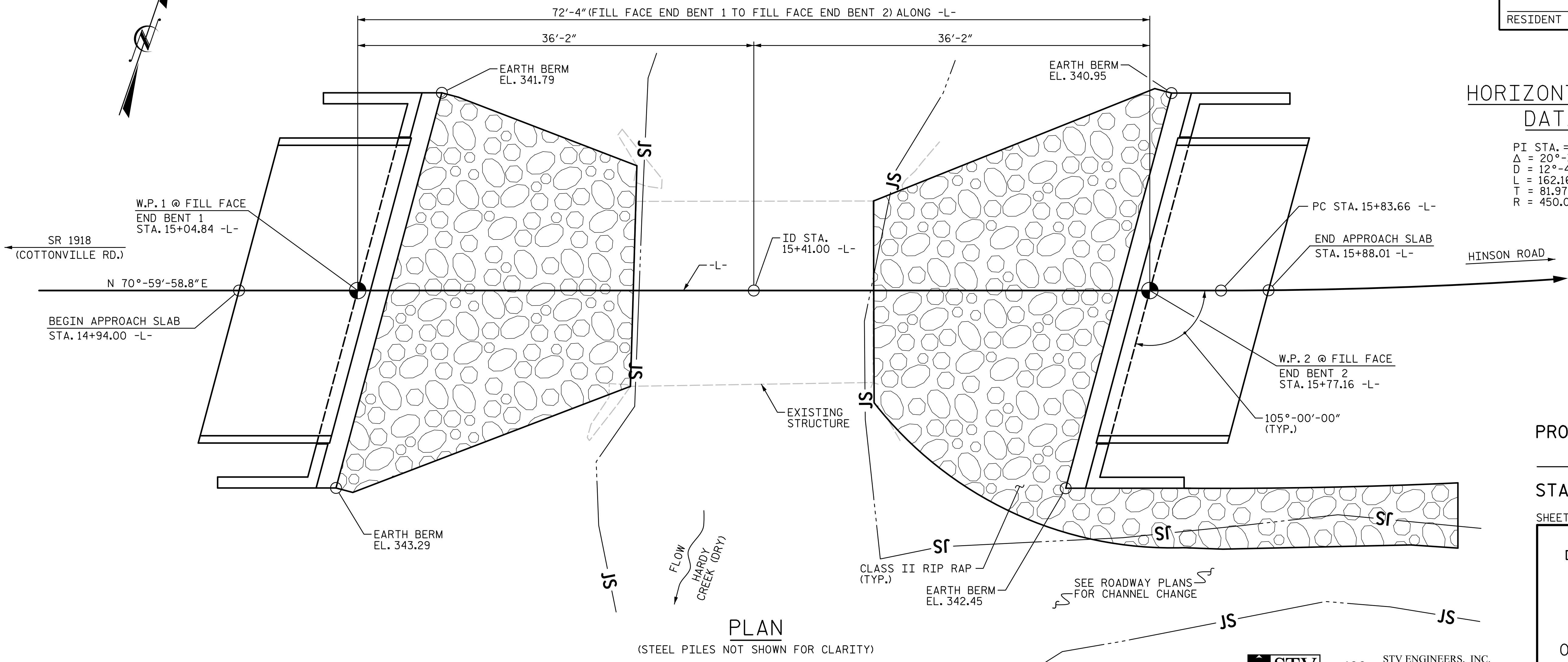

PLAN

(STEEL PILES NOT SHOWN FOR CLARITY)

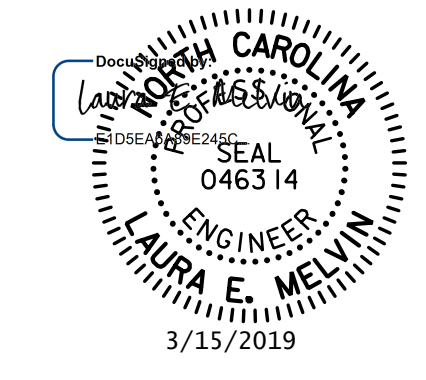

PROJECT NO. 17BP.10.R.133
STANLY COUNTY
 STATION: 15+41.00 -L-
 SHEET 1 OF 2 REPLACES BRIDGE NO. 162

STATE OF NORTH CAROLINA
 DEPARTMENT OF TRANSPORTATION
 RALEIGH
GENERAL DRAWING
 FOR BRIDGE ON SR 1923
 (OLD COTTONVILLE ROAD)
 OVER HARDY CREEK BETWEEN
 SR 1918 AND HINSON ROAD

REVISIONS				SHEET NO.	
NO.	BY:	DATE:	NO.	BY:	DATE:
1			3		
2			4		

TOTAL SHEETS: 16

STV 100 YEARS
 STV ENGINEERS, INC.
 900 West Trade St., Suite 715
 Charlotte, NC 28202
 NC License Number F-0991

DOCUMENT NOT CONSIDERED FINAL UNLESS ALL SIGNATURES COMPLETED

R:\Structures\ustation\Finals\40L\00L\7BP.10.R.133_SMU_GDL_001_830162.dgn 10:20:23 AM 3/14/2019 MeivnLE

DRAWN BY : CL DATE : 10-18
 CHECKED BY : LEM DATE : 11-18
 DESIGN ENGINEER OF RECORD : LEM DATE : 12-18

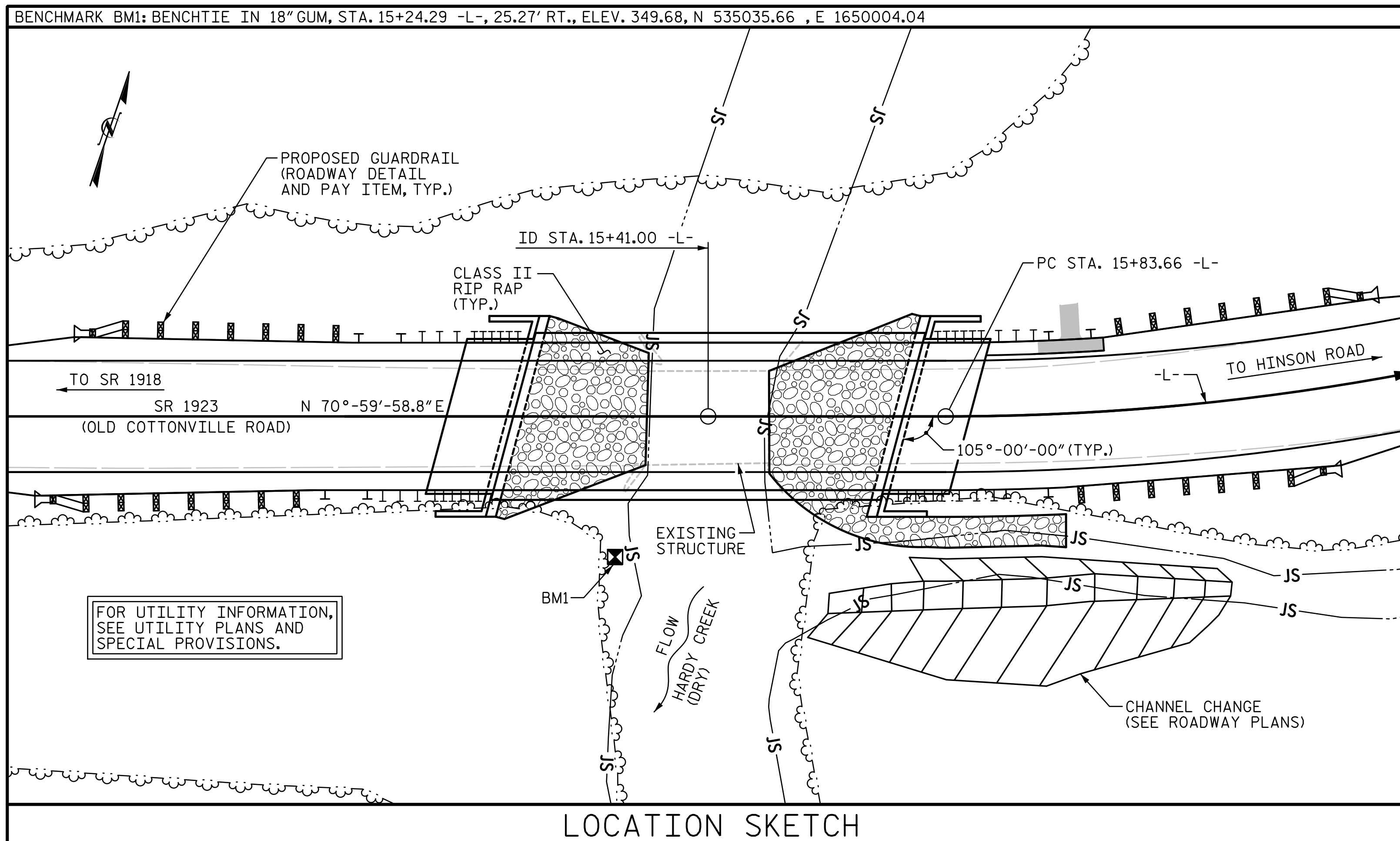

GENERAL NOTES

ASSUMED LIVE LOAD = HL-93 OR ALTERNATE LOADING.

THIS BRIDGE HAS BEEN DESIGNED IN ACCORDANCE WITH THE REQUIREMENTS OF THE AASHTO LRFD BRIDGE DESIGN SPECIFICATIONS.

THIS BRIDGE IS LOCATED IN SEISMIC ZONE 1.

FOR OTHER DESIGN DATA AND GENERAL NOTES, SEE "STANDARD NOTES" SHEET.

FOR EROSION CONTROL MEASURES, SEE EROSION CONTROL PLANS.

THE EXISTING STRUCTURE CONSISTING OF (1) 25'-8" SPAN WITH A TIMBER DECK ON STEEL I-BEAMS AND CHANNELS WITH A CLEAR ROADWAY WIDTH OF 15'-10"± AND SUPPORTED BY MASS CONCRETE ABUTMENTS AND LOCATED AT THE SITE OF THE PROPOSED STRUCTURE SHALL BE REMOVED. THE EXISTING BRIDGE IS PRESENTLY POSTED FOR LOAD LIMIT. SHOULD THE STRUCTURAL INTEGRITY OF THE BRIDGE DETERIORATE DURING CONSTRUCTION OF THE PROPOSED BRIDGE, A LOAD LIMIT MAY BE POSTED AND MAY BE REDUCED AS FOUND NECESSARY DURING THE LIFE OF THE PROJECT.

REMOVAL OF THE EXISTING BRIDGE SHALL BE PERFORMED SO AS NOT TO ALLOW DEBRIS TO FALL INTO THE WATER. THE CONTRACTOR SHALL REMOVE THE BRIDGE AND SUBMIT DEMOLITION PLANS FOR REVIEW AND REMOVE THE BRIDGE IN ACCORDANCE WITH ARTICLE 402-2 OF THE STANDARD SPECIFICATIONS.

INASMUCH AS THE PAINT SYSTEM ON THE EXISTING STRUCTURAL STEEL CONTAINS LEAD, THE CONTRACTOR'S ATTENTION IS DIRECTED TO ARTICLE 107-1 OF THE STANDARD SPECIFICATIONS. ANY COSTS RESULTING FROM COMPLIANCE WITH APPLICABLE STATE OR FEDERAL REGULATIONS PERTAINING TO HANDLING OF MATERIALS CONTAINING LEAD BASED PAINT SHALL BE INCLUDED IN THE BID PRICE FOR 'REMOVAL OF EXISTING STRUCTURE AT STATION 15+41.00 -L-'.

THE MATERIAL SHOWN IN THE CROSS-HATCHED AREA (ON SHEET 1 OF 2) SHALL BE EXCAVATED FOR A DISTANCE FROM THE CENTERLINE OF ROADWAY OF 52'± (LEFT) AND 82'± (RIGHT) AT END BENT 1 AND 65'± (LEFT) AND 21'± (RIGHT) AT END BENT 2, AND TO AN ELEVATION OF 344±, AS DIRECTED BY THE ENGINEER. THIS WORK WILL BE PAID FOR AT THE CONTRACT LUMP SUM PRICE FOR UNCLASSIFIED STRUCTURE EXCAVATION. SEE SECTION 412 OF THE STANDARD SPECIFICATIONS.

THIS STRUCTURE HAS BEEN DESIGNED IN ACCORDANCE WITH "HEC 18 - EVALUATING SCOUR AT BRIDGES".

THE SUBSTRUCTURE OF THE EXISTING BRIDGE INDICATED ON THE PLANS IS FROM THE BEST INFORMATION AVAILABLE. SINCE THIS INFORMATION IS SHOWN FOR THE CONVENIENCE OF THE CONTRACTOR, THE CONTRACTOR SHALL HAVE NO CLAIM WHATSOEVER AGAINST THE DEPARTMENT OF TRANSPORTATION FOR ANY DELAYS OR ADDITIONAL COST INCURRED BASED ON DIFFERENCES BETWEEN THE EXISTING BRIDGE SUBSTRUCTURE SHOWN ON THE PLANS AND THE ACTUAL CONDITIONS AT THE PROJECT SITE.

AT THE CONTRACTOR'S OPTION, PRESTRESSED CONCRETE END BENT CAPS MAY BE SUBSTITUTED IN PLACE OF THE CAST-IN-PLACE CAPS. THE CONTRACTOR SHALL COORDINATE WITH THE RESIDENT ENGINEER TO RECEIVE REVISED PLANS AND DETAILS FROM THE STRUCTURES MANAGEMENT UNIT. THE REDESIGN AND ANY ADDITIONAL MATERIALS NEEDED WILL BE AT NO ADDITIONAL COST TO THE CONTRACTOR.

FOR SUBMITTAL OF WORKING DRAWINGS, SEE SPECIAL PROVISIONS.

FOR FALSEWORK AND FORMWORK, SEE SPECIAL PROVISIONS.

FOR CRANE SAFETY, SEE SPECIAL PROVISIONS.

FOR GROUT FOR STRUCTURES, SEE SPECIAL PROVISIONS.

ASPHALT WEARING SURFACE IS INCLUDED IN ROADWAY QUANTITY ON ROADWAY PLANS.

FOR ASBESTOS ASSESSMENT FOR BRIDGE DEMOLITION AND RENOVATION ACTIVITIES, SEE SPECIAL PROVISIONS.

HYDRAULIC DATA

DESIGN DISCHARGE: 600 CFS
 FREQUENCY OF DESIGN FLOOD: 2 YRS.
 DESIGN HIGH WATER ELEVATION: 348.6
 DRAINAGE AREA: 6.8 SQ. MI.
 BASE DISCHARGE (Q100): 2681 CFS
 BASE HIGH WATER ELEVATION: 351.9

OVERTOPPING DATA

OVERTOPPING DISCHARGE: 1,100 CFS
 FREQUENCY OF OVERTOPPING: 5± YRS.
 OVERTOPPING FLOOD ELEVATION: 349.1
 OVERTOPS @ STA. 16+30.39 -L-

TOTAL BILL OF MATERIAL						
	REMOVAL OF EXISTING STRUCTURE AT STA. 15+41.00 -L-	ASBESTOS ASSESSMENT	PILE EXCAVATION IN SOIL	PILE EXCAVATION NOT IN SOIL	UNCLASSIFIED STRUCTURE EXCAVATION	CLASS A CONCRETE
	LUMP SUM	LUMP SUM	LIN. FT.	LIN. FT.	LUMP SUM	CU. YD.
SUPERSTRUCTURE						
END BENT 1			0	28		20.9
END BENT 2			18	33		20.9
TOTAL	LUMP SUM	LUMP SUM	18	61	LUMP SUM	41.8

TOTAL BILL OF MATERIAL (CONT'D)

	BRIDGE APPROACH SLABS	REINFORCING STEEL	PILE DRIVING EQUIPMENT SETUP FOR HP 12 X 53 STEEL PILES	HP 12 X 53 STEEL PILES	42" OREGON RAIL	RIP RAP CLASS II (2'-0" THICK)	GEOTEXTILE FOR DRAINAGE	ELASTOMERIC BEARINGS	3'-0" X 2'-0" PRESTRESSED CONCRETE CORED SLABS		
	LUMP SUM	LBS.	EA.	NO.	LIN. FT.	LIN. FT.	TONS	SQ. YDS.	LUMP SUM	NO.	LIN. FT.
SUPERSTRUCTURE						140.0				10	700.0
END BENT 1		2,546	5	5	39		65	75			
END BENT 2		2,546	5	5	62		100	110			
TOTAL	LUMP SUM	5,092	10	10	101	140.0	165	185	LUMP SUM	10	700.0

FOUNDATION NOTES

FOR PILES, SEE SECTION 450 OF THE STANDARD SPECIFICATIONS.

PILES AT END BENT 1 ARE DESIGNED FOR A FACTORED RESISTANCE OF 99 TONS PER PILE.

DRIVE PILES AT END BENT 1 TO A REQUIRED DRIVING RESISTANCE OF 165 TONS PER PILE.

DRILLED-IN PILES ARE REQUIRED FOR END BENT 1. EXCAVATE HOLES AT PILE LOCATIONS TO ELEVATION 338 FT. FOR PILE EXCAVATION, SEE SECTION 450 OF THE STANDARD SPECIFICATIONS.

PILES AT END BENT 2 ARE DESIGNED FOR A FACTORED RESISTANCE OF 99 TONS PER PILE.

DRIVE PILES AT END BENT 2 TO A REQUIRED DRIVING RESISTANCE OF 165 TONS PER PILE.

DRILLED-IN PILES ARE REQUIRED FOR END BENT 2. EXCAVATE HOLES AT PILE LOCATIONS TO ELEVATION 332.5 FT. FOR PILE EXCAVATION, SEE SECTION 450 OF THE STANDARD SPECIFICATIONS.

CONCRETE IS REQUIRED TO FILL HOLES FOR PILE EXCAVATION AT END BENTS 1 AND 2.

PROJECT NO. 17BP.10.R.133
STANLY COUNTY
 STATION: 15+41.00 -L-

SHEET 2 OF 2

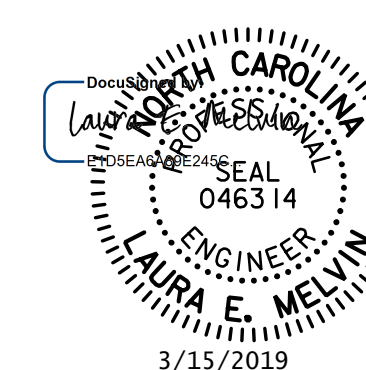

STV 100 YEARS
 STV ENGINEERS, INC.
 900 West Trade St., Suite 715
 Charlotte, NC 28202
 NC License Number F-0991

DOCUMENT NOT CONSIDERED FINAL UNLESS ALL SIGNATURES COMPLETED

STATE OF NORTH CAROLINA
 DEPARTMENT OF TRANSPORTATION
 RALEIGH

GENERAL DRAWING

FOR BRIDGE ON SR 1923 (OLD COTTONVILLE ROAD) OVER HARDY CREEK BETWEEN SR 1918 AND HINSON ROAD

REVISIONS				SHEET NO.		
NO.	BY:	DATE:	NO.	BY:	DATE:	S-2
1			3			TOTAL SHEETS 16
2			4			

DRAWN BY: CL DATE: 10-18
 CHECKED BY: LEM DATE: 11-18
 DESIGN ENGINEER OF RECORD: LEM DATE: 12-18

R:\Structures\ustation\Finals\401_003_17BP.10.R.133_SML.GD2_002_830162.dgn 3/14/2019 10:45 AM MevinLE

LOAD AND RESISTANCE FACTOR RATING (LRFD) SUMMARY FOR PRESTRESSED CONCRETE GIRDERS

LEVEL	VEHICLE	WEIGHT (W) (TONS)	CONTROLLING LOAD RATING	MINIMUM RATING FACTORS (RF)	TONS = W X RF	STRENGTH I LIMIT STATE										SERVICE III LIMIT STATE					COMMENT NUMBER			
						MOMENT					SHEAR					MOMENT								
						LIVELOAD FACTORS	DISTRIBUTION FACTORS (DF)	RATING FACTOR	SPAN	GIRDER LOCATION	DISTANCE FROM LEFT END OF SPAN (ft)	DISTRIBUTION FACTORS (DF)	RATING FACTOR	SPAN	GIRDER LOCATION	DISTANCE FROM LEFT END OF SPAN (ft)	LIVELOAD FACTORS	DISTRIBUTION FACTORS (DF)	RATING FACTOR	SPAN		GIRDER LOCATION	DISTANCE FROM LEFT END OF SPAN (ft)	
DESIGN LOAD RATING	HL-93(Inv)	N/A	1	1.014	--	1.75	0.269	1.04	70'	EL	34.482	0.608	1.10	70'	EL	3.448	0.80	0.269	1.01	70'	EL	34.482		
	HL-93(Opr)	N/A	--	1.355	--	1.35	0.269	1.35	70'	EL	34.482	0.608	1.43	70'	EL	3.448	N/A	--	--	--	--	--		
	HS-20(Inv)	36.000	2	1.315	47.356	1.75	0.269	1.36	70'	EL	34.482	0.608	1.38	70'	EL	3.448	0.80	0.269	1.32	70'	EL	34.482		
	HS-20(Opr)	36.000	--	1.757	63.236	1.35	0.269	1.76	70'	EL	34.482	0.608	1.79	70'	EL	3.448	N/A	--	--	--	--	--		
LEGAL LOAD RATING	SV	SNSH	13.500	--	2.938	39.656	1.4	0.269	3.78	70'	EL	34.482	0.608	4.12	70'	EL	3.448	0.80	0.269	2.94	70'	EL	34.482	
		SNGARBS2	20.000	--	2.203	44.052	1.4	0.269	2.84	70'	EL	34.482	0.608	2.93	70'	EL	3.448	0.80	0.269	2.20	70'	EL	34.482	
		SNAGRIS2	22.000	--	2.092	46.016	1.4	0.269	2.69	70'	EL	34.482	0.608	2.72	70'	EL	3.448	0.80	0.269	2.09	70'	EL	34.482	
		SNCOTTS3	27.250	--	1.462	39.844	1.4	0.269	1.88	70'	EL	34.482	0.608	2.06	70'	EL	3.448	0.80	0.269	1.46	70'	EL	34.482	
		SNAGGRS4	34.925	--	1.227	42.856	1.4	0.269	1.58	70'	EL	34.482	0.608	1.71	70'	EL	3.448	0.80	0.269	1.23	70'	EL	34.482	
		SNS5A	35.550	--	1.200	42.646	1.4	0.269	1.54	70'	EL	34.482	0.608	1.73	70'	EL	3.448	0.80	0.269	1.20	70'	EL	34.482	
		SNS6A	39.950	--	1.103	44.058	1.4	0.269	1.42	70'	EL	34.482	0.608	1.58	70'	EL	3.448	0.80	0.269	1.10	70'	EL	34.482	
	TTST	TNAGRIT3	33.000	--	1.345	44.401	1.4	0.269	1.73	70'	EL	34.482	0.608	1.88	70'	EL	3.448	0.80	0.269	1.35	70'	EL	34.482	
		TNT4A	33.075	--	1.352	44.717	1.4	0.269	1.74	70'	EL	34.482	0.608	1.83	70'	EL	3.448	0.80	0.269	1.35	70'	EL	34.482	
		TNT6A	41.600	--	1.108	46.073	1.4	0.269	1.43	70'	EL	34.482	0.608	1.65	70'	EL	3.448	0.80	0.269	1.11	70'	EL	34.482	
		TNT7A	42.000	--	1.114	46.794	1.4	0.269	1.43	70'	EL	34.482	0.608	1.62	70'	EL	3.448	0.80	0.269	1.11	70'	EL	34.482	
		TNT7B	42.000	--	1.155	48.526	1.4	0.269	1.49	70'	EL	34.482	0.608	1.51	70'	EL	3.448	0.80	0.269	1.16	70'	EL	34.482	
		TNAGRIT4	43.000	--	1.097	47.174	1.4	0.269	1.41	70'	EL	34.482	0.608	1.46	70'	EL	3.448	0.80	0.269	1.10	70'	EL	34.482	
		TNAGT5A	45.000	--	1.033	46.505	1.4	0.269	1.33	70'	EL	34.482	0.608	1.45	70'	EL	3.448	0.80	0.269	1.03	70'	EL	34.482	
TNAGT5B	45.000	3	1.020	45.905	1.4	0.269	1.31	70'	EL	34.482	0.608	1.39	70'	EL	3.448	0.80	0.269	1.02	70'	EL	34.482			

LOAD FACTORS:

DESIGN LOAD RATING FACTORS	LIMIT STATE	γ_{DC}	γ_{DW}
	STRENGTH I	1.25	1.50
	SERVICE III	1.00	1.00

NOTES:

MINIMUM RATING FACTORS ARE BASED ON THE STRENGTH I AND SERVICE III LIMIT STATES.
ALLOWABLE STRESSES FOR SERVICE III LIMIT STATE ARE AS REQUIRED FOR DESIGN.

COMMENTS:

- 1.
- 2.
- 3.
- 4.

CONTROLLING LOAD RATING

1 DESIGN LOAD RATING (HL-93)

2 DESIGN LOAD RATING (HS-20)

3 LEGAL LOAD RATING **

** SEE CHART FOR VEHICLE TYPE

GIRDER LOCATION

I - INTERIOR GIRDER
EL - EXTERIOR LEFT GIRDER
ER - EXTERIOR RIGHT GIRDER

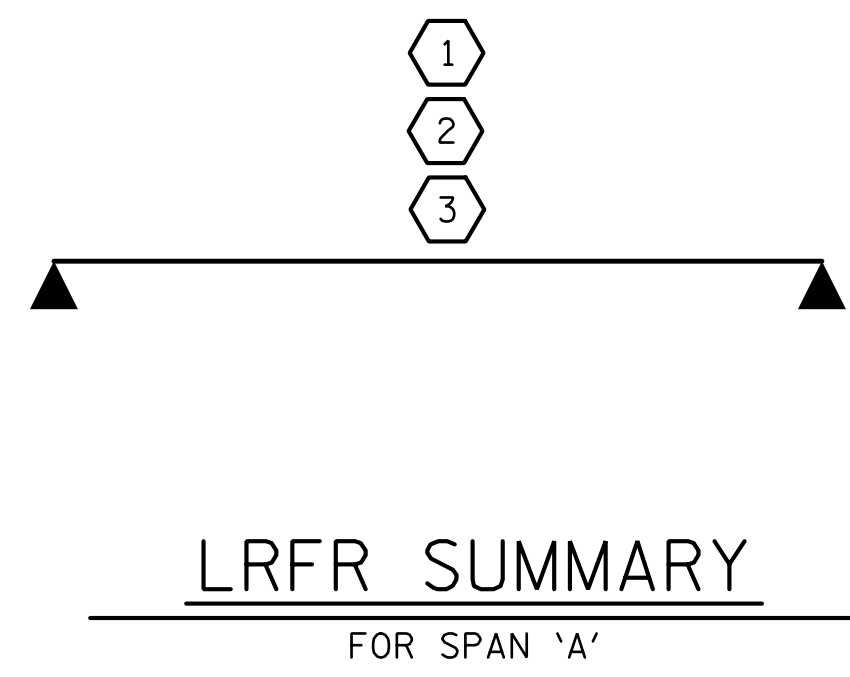

PROJECT NO. 17BP.10.R.133
STANLY COUNTY
STATION: 15+41.00 -L-

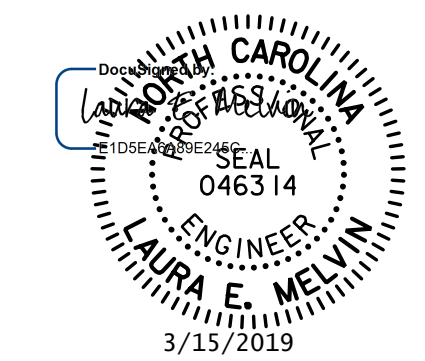

STV 100 YEARS
STV ENGINEERS, INC.
900 West Trade St., Suite 715
Charlotte, NC 28202
NC License Number F-0991

DOCUMENT NOT CONSIDERED
FINAL UNLESS ALL
SIGNATURES COMPLETED

STATE OF NORTH CAROLINA
DEPARTMENT OF TRANSPORTATION
RALEIGH
STANDARD
LRFR SUMMARY FOR
70' CORED SLAB UNIT
105° SKEW
(NON-INTERSTATE TRAFFIC)

REVISIONS				SHEET NO.
NO.	BY:	DATE:	NO.	DATE:
1			3	
2			4	
				S-3
				TOTAL SHEETS 16

R:\Structures\ustation\Finals\40L_005_17BP_10.R.133_SML_LRFR_003_830162.dgn 3/14/2019 10:17:07 AM MeivnLE

ASSEMBLED BY : CL DATE : 10-18
CHECKED BY : LEM DATE : 11-18
DESIGN ENGINEER OF RECORD : LEM DATE : 12-18
DRAWN BY : CVC 6/10
CHECKED BY : DNS 6/10

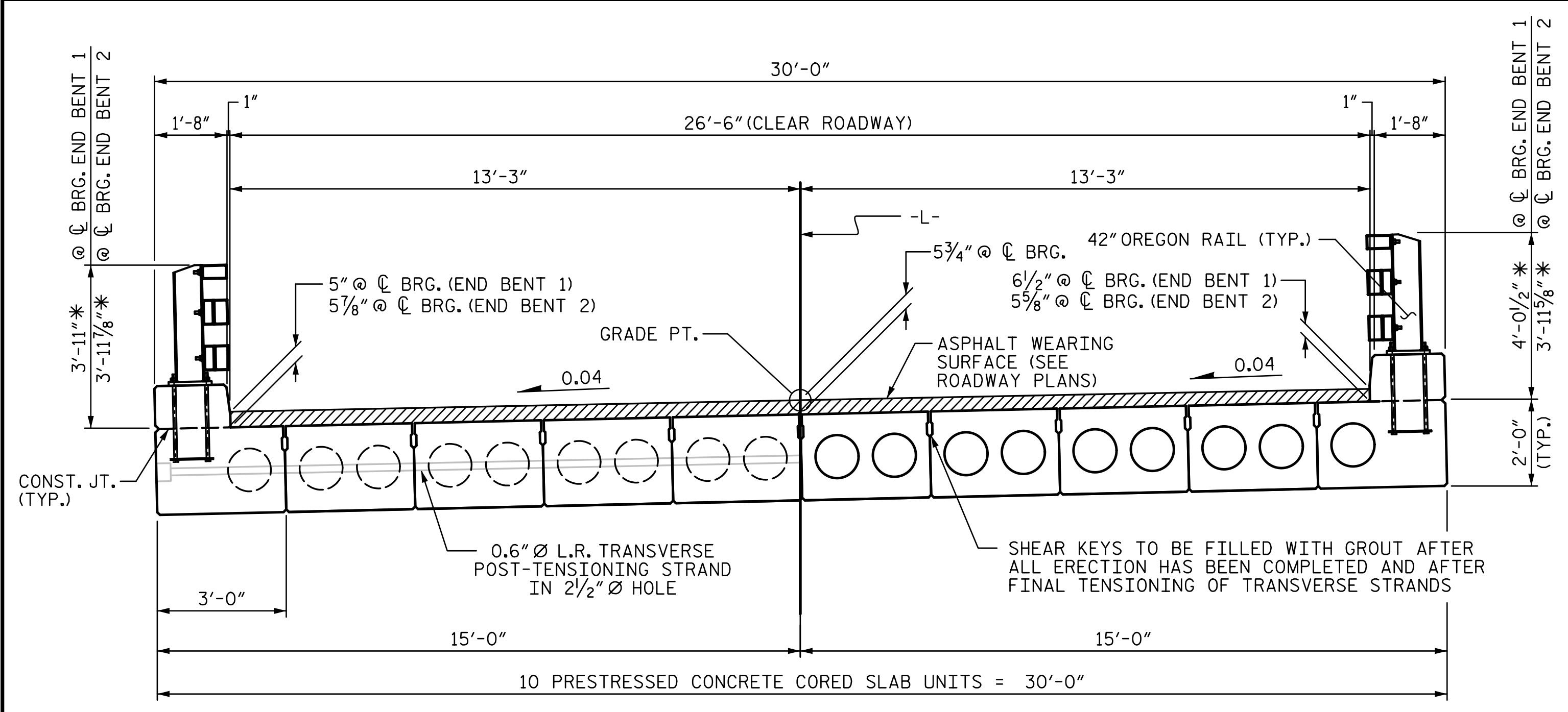

HALF SECTION AT INTERMEDIATE DIAPHRAGMS
TYPICAL SECTION
 HALF SECTION THROUGH VOIDS

* - THE MAXIMUM OREGON RAIL HEIGHT, CONCRETE CURB HEIGHT AND ASPHALT THICKNESS ARE SHOWN. THE HEIGHT OF THE CONCRETE CURB AND ASPHALT THICKNESS VARY WHILE THE TOP OF THE OREGON RAIL FOLLOWS THE PROFILE OF THE GUTTERLINE. FOR CONCRETE CURB HEIGHT DETAILS AND ASPHALT THICKNESS, SEE THE "CONCRETE CURB DETAILS" ON SHEET 3 OF 4.

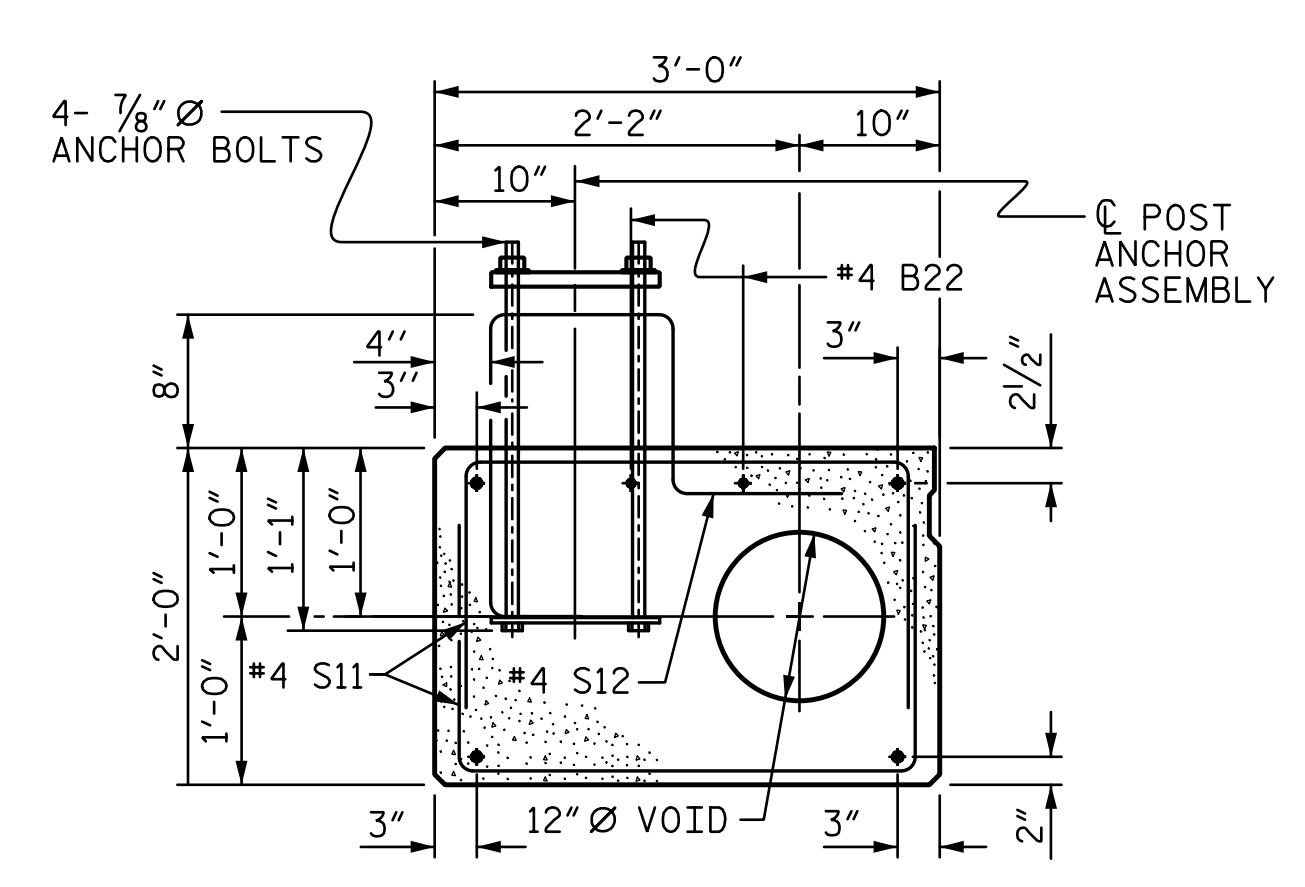

EXTERIOR SLAB SECTION
 (FOR PRESTRESSED STRAND LAYOUT, SEE INTERIOR SLAB SECTION.)

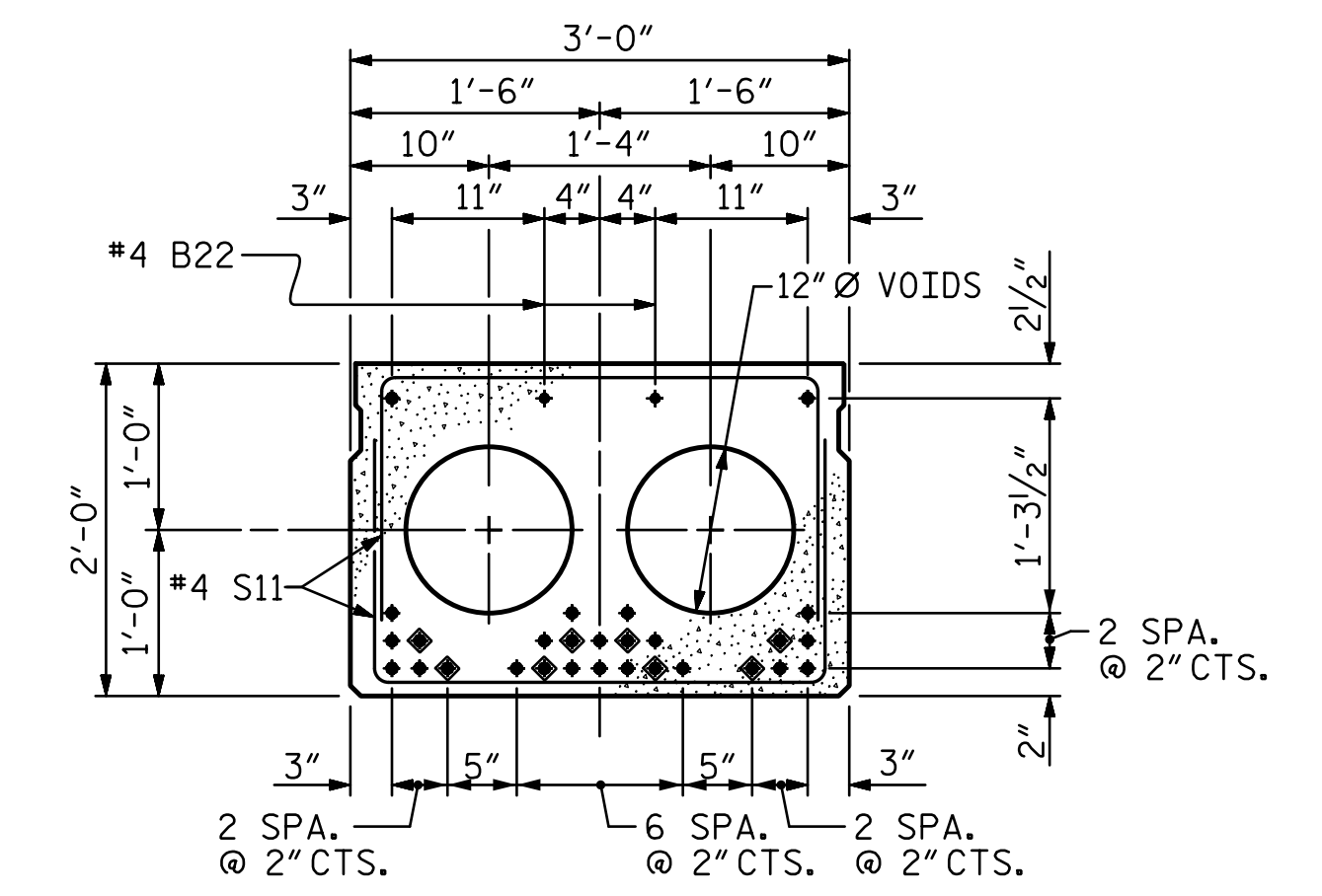

INTERIOR SLAB SECTION
 (28 STRANDS REQUIRED)

0.6" Ø LOW RELAXATION STRAND LAYOUT

◆ BOND SHALL BE BROKEN ON THESE STRANDS FOR A DISTANCE OF 12'-0" FROM END OF CORED SLAB UNIT. SEE STANDARD SPECIFICATIONS, ARTICLE 1078-7.

DEBONDING LEGEND

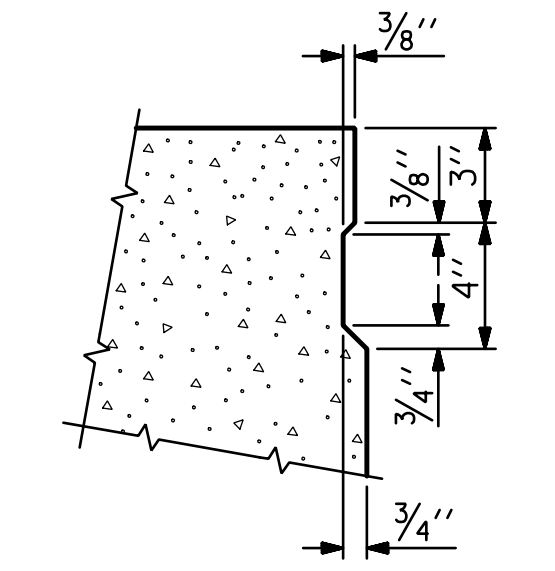

SHEAR KEY DETAIL
 NOTE: OMIT SHEAR KEY ON OUTSIDE FACE OF EXTERIOR CORED SLABS.

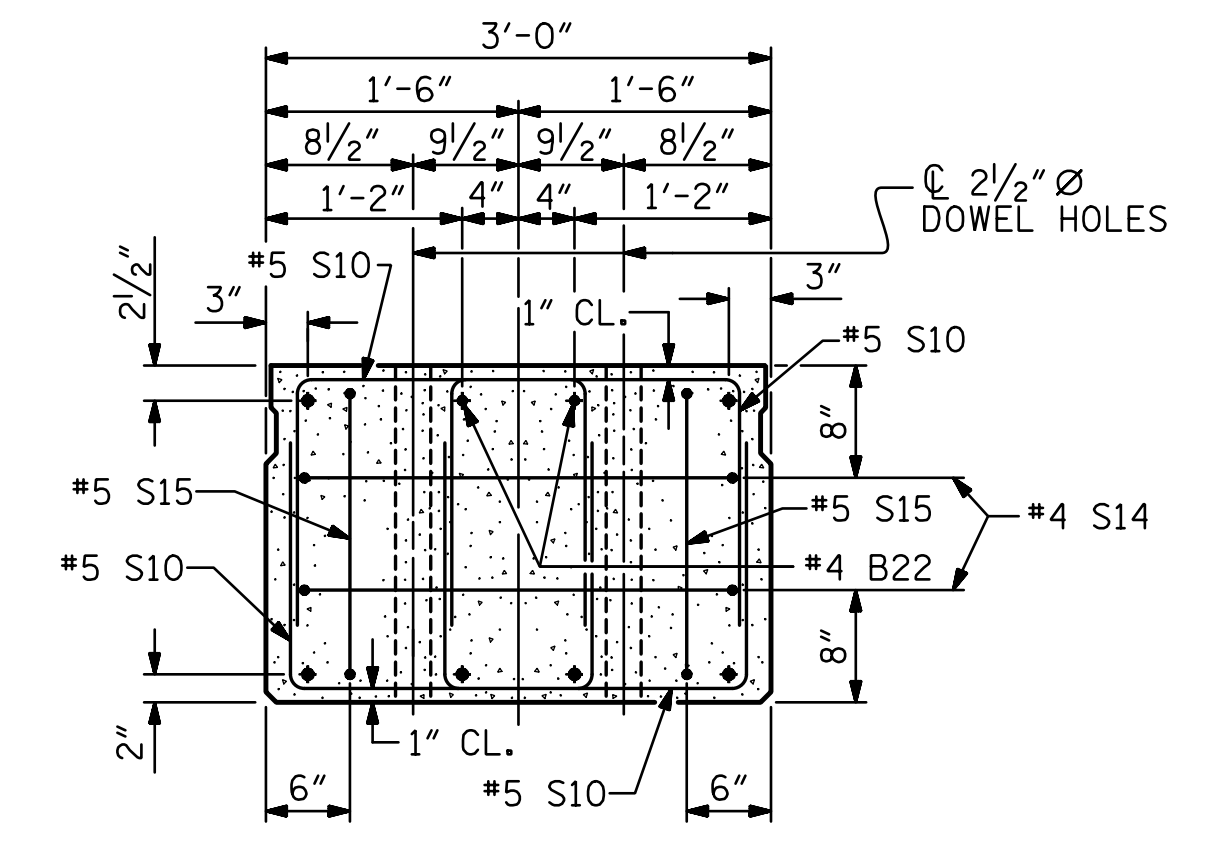

END ELEVATION
 SHOWING PLACEMENT OF DOUBLE STIRRUPS AND LOCATION OF DOWEL HOLES. (STRAND LAYOUT NOT SHOWN.) INTERIOR SLAB UNIT SHOWN-EXTERIOR SLAB UNIT SIMILAR EXCEPT SHEAR KEY LOCATION.

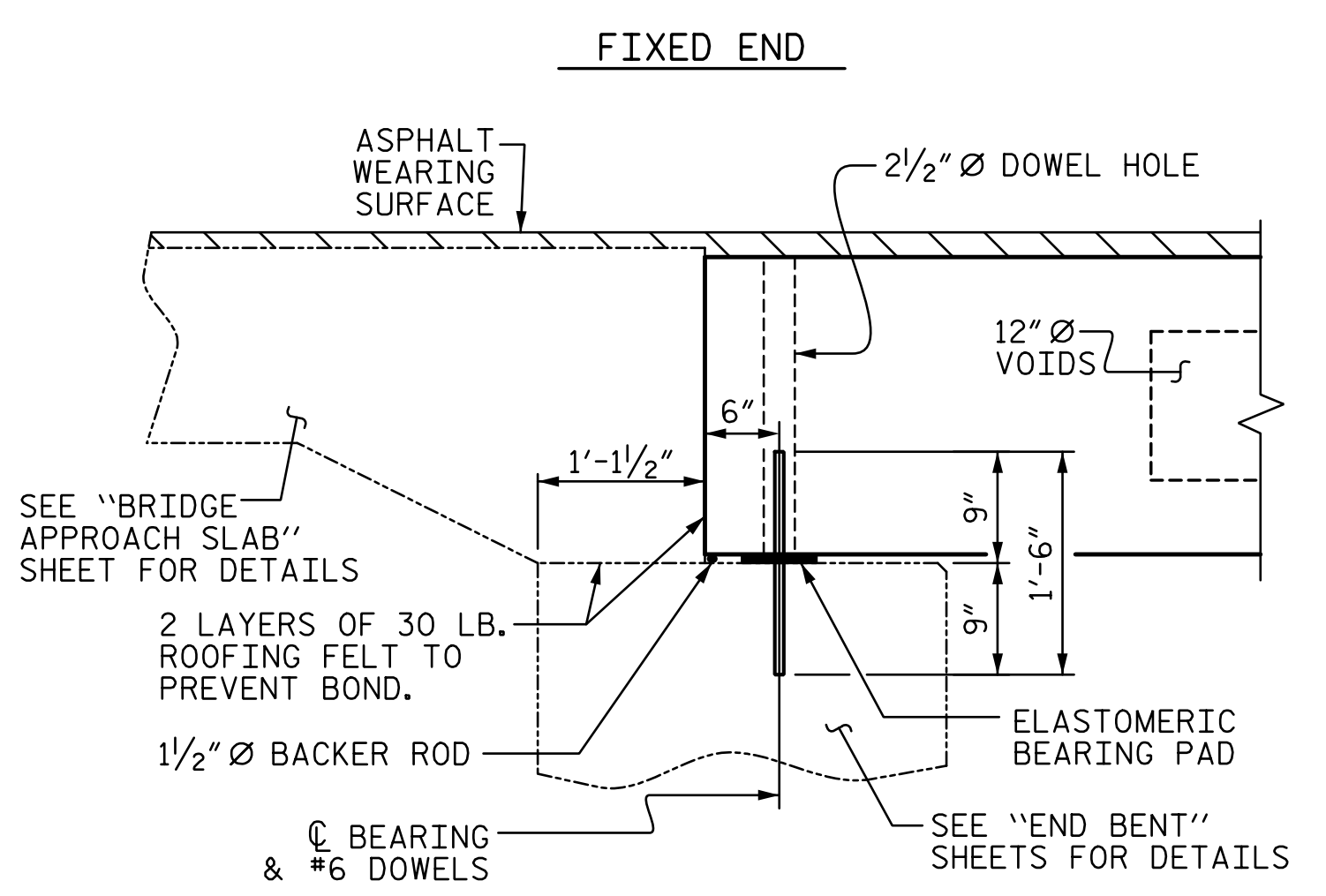

SECTION AT END BENT

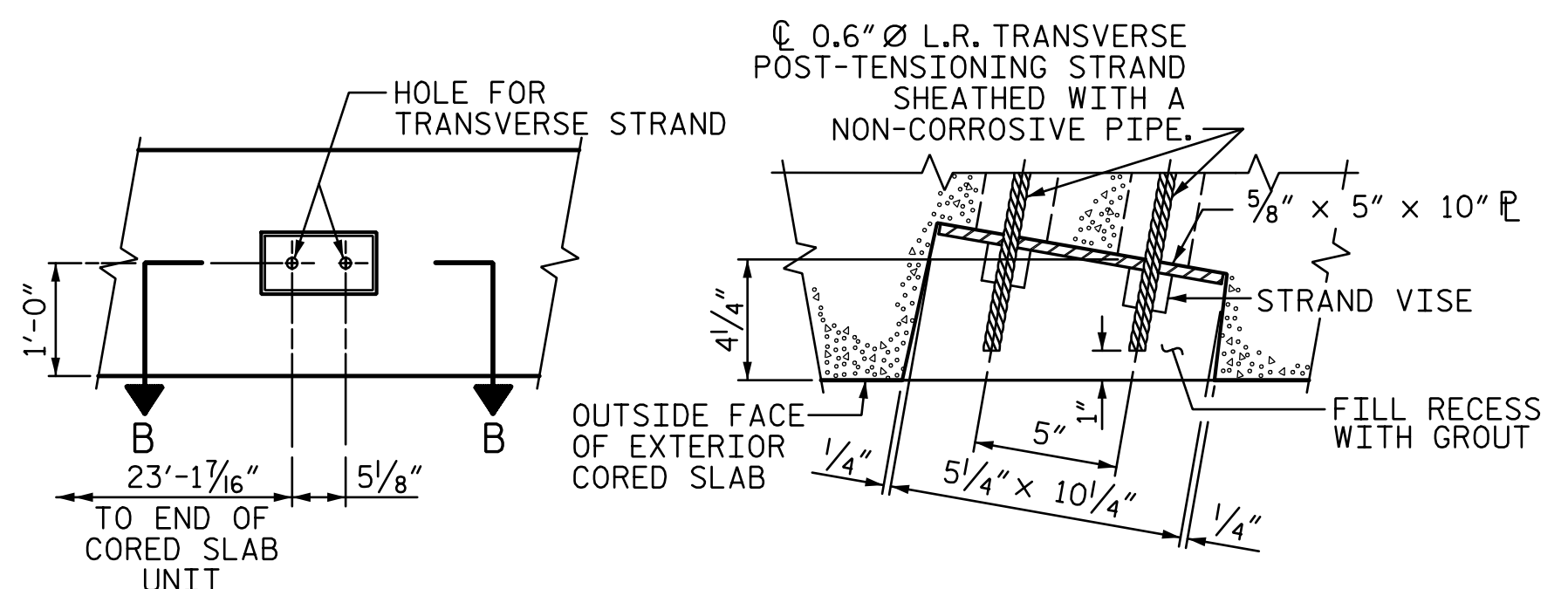

ELEVATION VIEW
SECTION B-B
GROUTED RECESS AT END OF POST-TENSIONED STRAND CORED SLABS

PERMITTED THREADED INSERT CAST IN OUTSIDE FACE OF EXTERIOR UNIT AND RECESSED 3/8" SIZE TO BE DETERMINED BY CONTRACTOR.

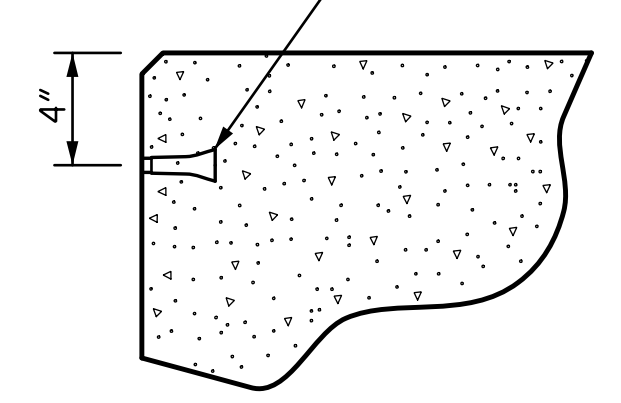

THREADED INSERT DETAIL

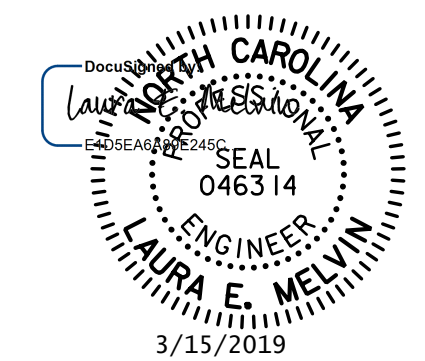

STV 100 YEARS
 STV ENGINEERS, INC.
 900 West Trade St., Suite 715
 Charlotte, NC 28202
 NC License Number F-0991

DOCUMENT NOT CONSIDERED FINAL UNLESS ALL SIGNATURES COMPLETED

PROJECT NO. 17BP.10.R.133
STANLY COUNTY
 STATION: 15+41.00 -L-
 SHEET 1 OF 4

STATE OF NORTH CAROLINA
 DEPARTMENT OF TRANSPORTATION
 RALEIGH
3'-0" X 2'-0" PRESTRESSED CONCRETE CORED SLAB UNIT

REVISIONS				SHEET NO.	
NO.	BY:	DATE:	NO.	BY:	DATE:
1			3		
2			4		

TOTAL SHEETS: 16

R:\Structures\ustation\Finals\40L_007_17BP.10.R.133_SML_CSL_004_830162.dgn 3/14/2019 10:17:09 AM MevlinLE

DRAWN BY : CL DATE : 10-18
 CHECKED BY : LEM DATE : 11-18
 DESIGN ENGINEER OF RECORD : LEM DATE : 12-18

R:\Structures\ustation\Finals\40L_009_17BP_10.R.133_SML_CS2_005_830162.dgn
3/14/2019 10:11:11 AM MeivlinLE

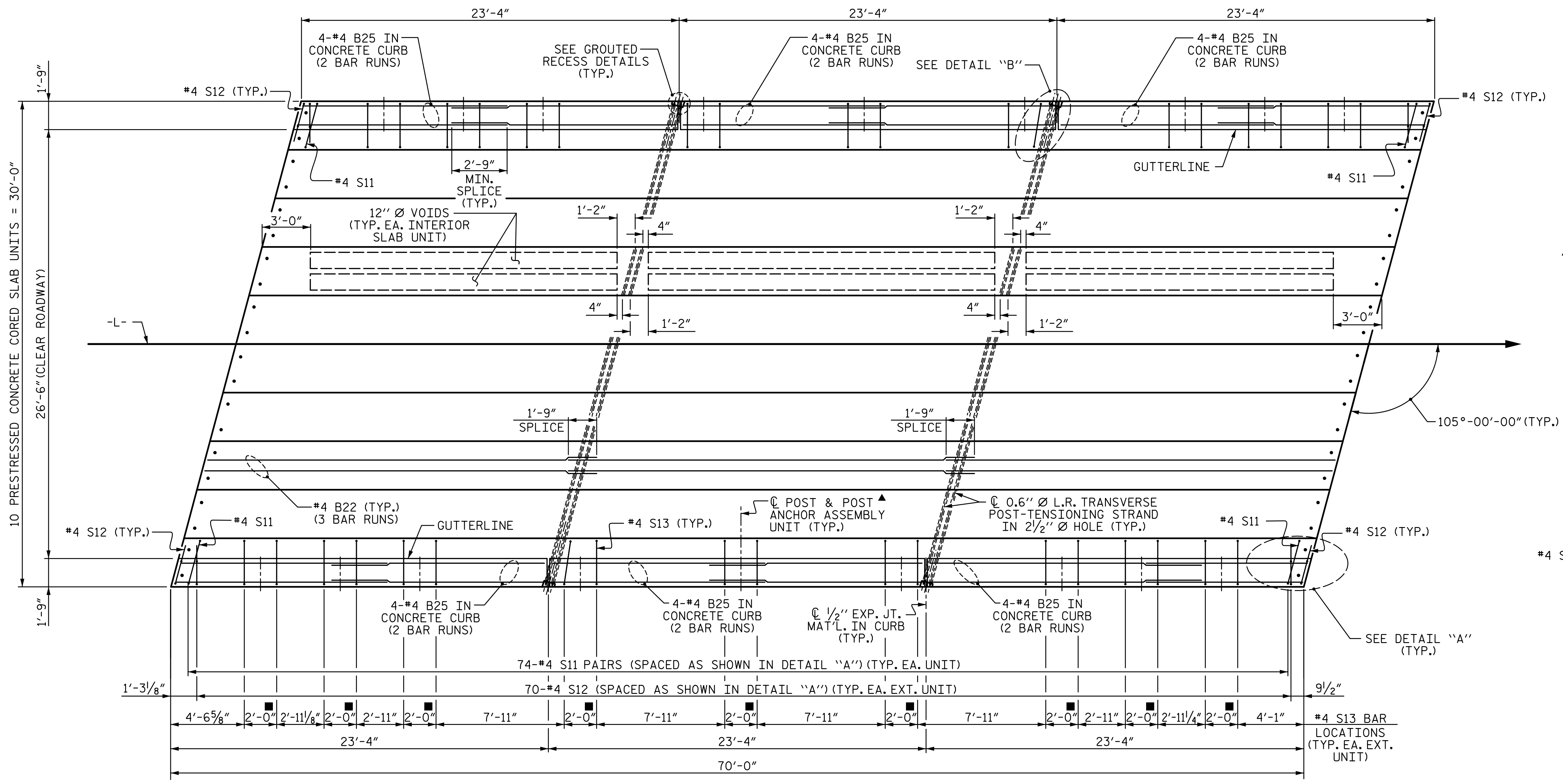

▲ FOR POST AND POST ANCHOR ASSEMBLY SPACING, SEE "RAIL POST SPACINGS AND END OF RAIL DETAILS" SHEET

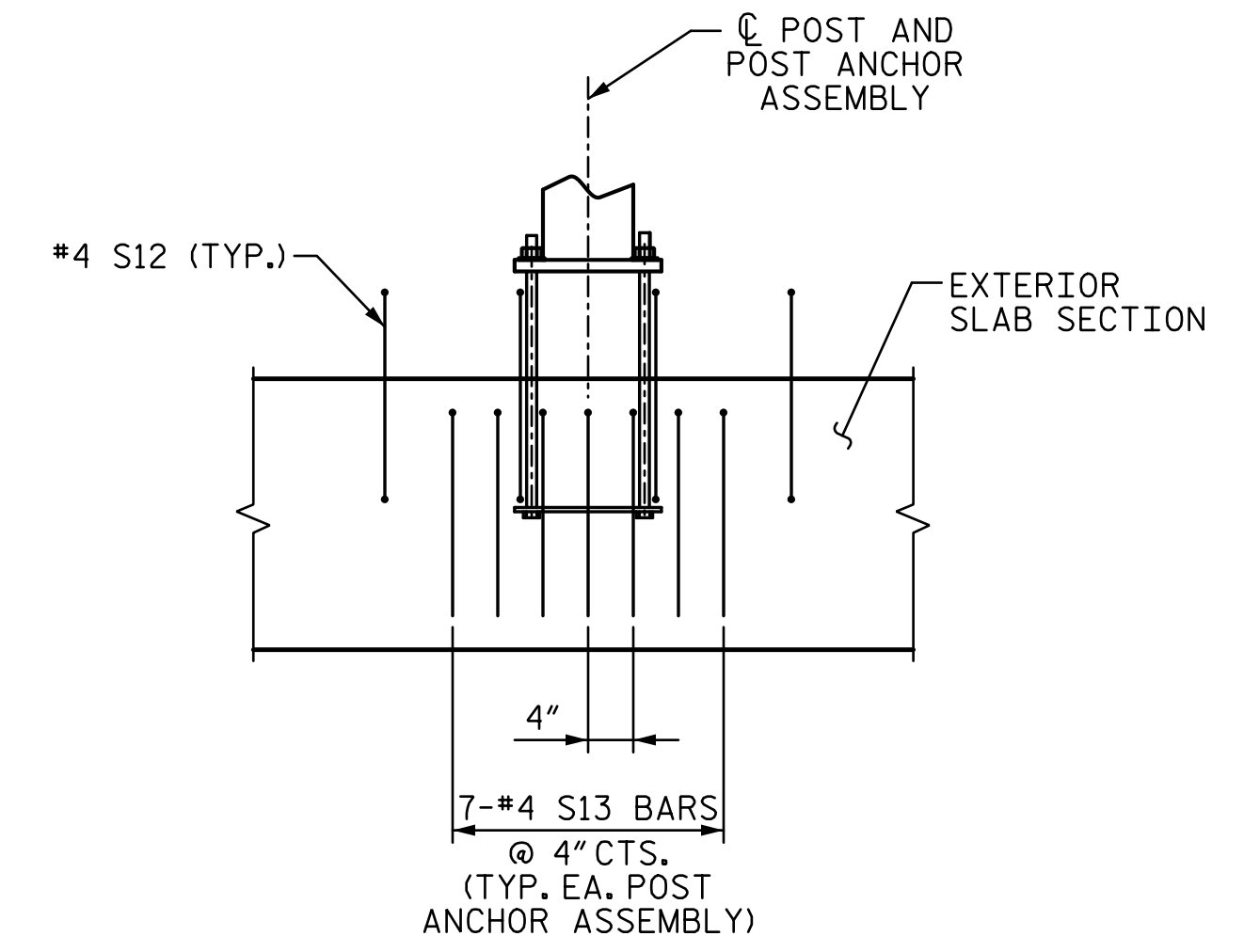

■ SIDE VIEW AT POST LOCATION (SHOWING ADDITIONAL S13 BARS AT EACH POST ANCHOR ASSEMBLY) #4 S11 NOT SHOWN FOR CLARITY. #4 S11 & #4 S12 MAY BE SHIFTED AS NECESSARY TO CLEAR ANCHOR BOLTS IN POST ANCHOR ASSEMBLY.

PLAN OF UNIT

■ SEE SIDE VIEW AT POST LOCATION FOR SPACING OF #4 S13 BARS

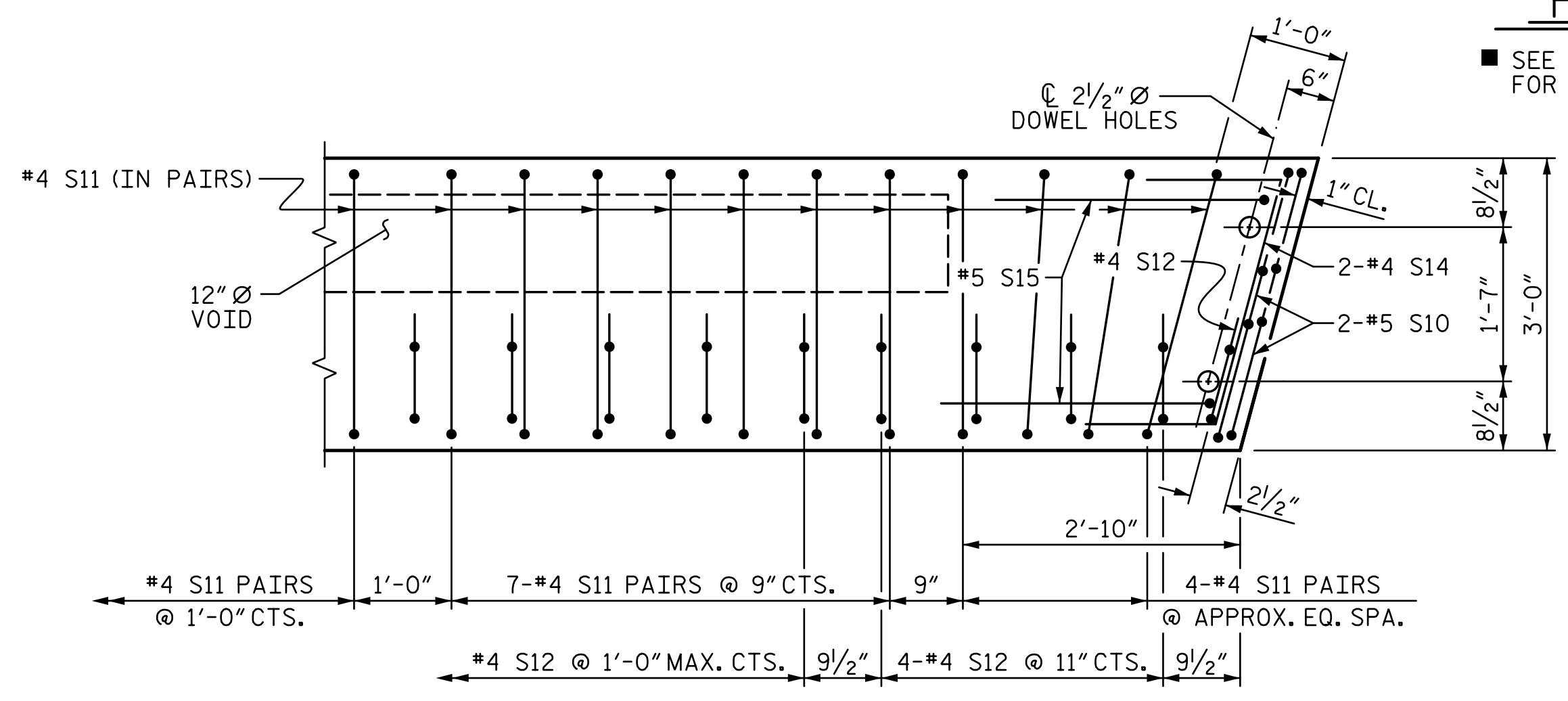

DETAIL "A"

(SIMILAR EACH END OF UNIT) #4 S13 IN EXTERIOR UNIT NOT SHOWN, SEE SIDE VIEW AT POST LOCATION AND PLAN OF UNIT FOR DETAILS NOTE: EXTERIOR UNIT SHOWN - INTERIOR UNIT SIMILAR EXCEPT OMIT #4 S12 & #4 S13 AND PROVIDE 2-12" Ø VOIDS.

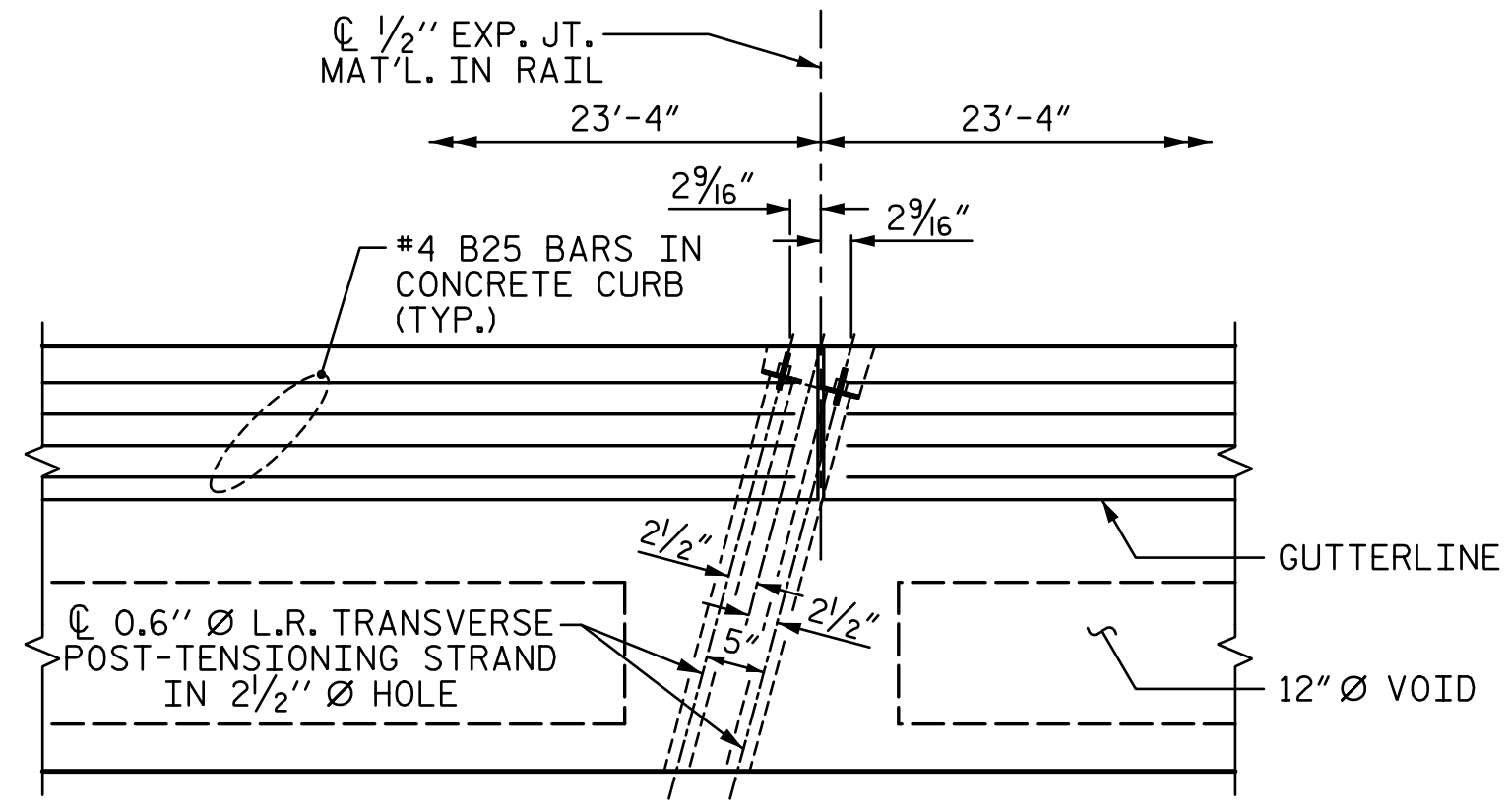

DETAIL "B"

#4 S11, #4 S12 & #4 S13 BARS MAY BE SHIFTED AS NECESSARY TO MAINTAIN 1" CLEAR TO GROUDED RECESS AND 2 1/2" Ø TRANSVERSE POST-TENSIONING STRAND HOLES

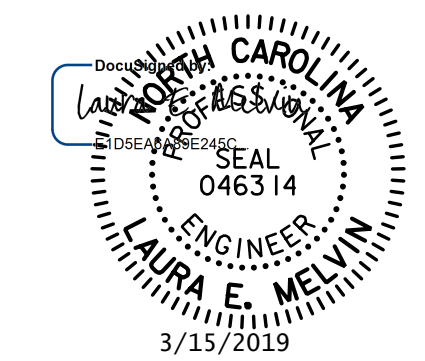

STV 100 YEARS STV ENGINEERS, INC. 900 West Trade St., Suite 715 Charlotte, NC 28202 NC License Number F-0991

DOCUMENT NOT CONSIDERED FINAL UNLESS ALL SIGNATURES COMPLETED

PROJECT NO. 17BP.10.R.133
STANLY COUNTY
STATION: 15+41.00 -L-
SHEET 2 OF 4

STATE OF NORTH CAROLINA DEPARTMENT OF TRANSPORTATION RALEIGH					SHEET NO. S-5
PLAN OF 70' UNIT 26'-6" CLEAR ROADWAY 105° SKEW					TOTAL SHEETS 16
REVISIONS					SHEET NO.
NO.	BY:	DATE:	NO.	BY:	
1			3		S-5
2			4		

DRAWN BY :	CL	DATE :	10-18
CHECKED BY :	LEM	DATE :	11-18
DESIGN ENGINEER OF RECORD :	LEM	DATE :	12-18

BILL OF MATERIAL FOR CURB & END POSTS					
BAR	NO.	SIZE	TYPE	LENGTH	WEIGHT
* B25	48	#4	STR	13'-2"	422
* E1	8	#7	STR	2'-11"	48
* E2	8	#7	STR	3'-2"	52
* E3	8	#7	STR	3'-5"	56
* E4	8	#7	STR	3'-8"	60
* E5	8	#7	STR	3'-11"	64
* F1	12	#6	STR	3'-5"	62
* F2	8	#6	STR	2'-3"	27
* F3	4	#6	STR	3'-7"	22
* F4	12	#6	STR	3'-9"	68
* F5	4	#6	STR	3'-11"	24
* EPOXY COATED REINFORCING STEEL					905 LBS.
CLASS AA CONCRETE					11.5 CU.YDS.
42" OREGON RAIL					140.0 LIN. FT.

GUTTERLINE ASPHALT THICKNESS, CURB HEIGHT AND END POST HEIGHT								
GUTTERLINE	ASPHALT OVERLAY THICKNESS			CURB HEIGHT			END POST HEIGHT	
	@ C. BRG. EB1	@ MID. -SPAN	@ C. BRG. EB2	@ C. BRG. EB1	@ MID. -SPAN	@ C. BRG. EB2	@ EB 1	@ EB 2
LEFT	5"	1 3/4"	5 5/8"	1'-1 1/2"	10 1/4"	1'-2 3/8"	4'-1"	4'-1 7/8"
RIGHT	6 1/2"	2 1/4"	5 5/8"	1'-3"	10 3/4"	1'-2 1/8"	4'-2 1/2"	4'-1 5/8"

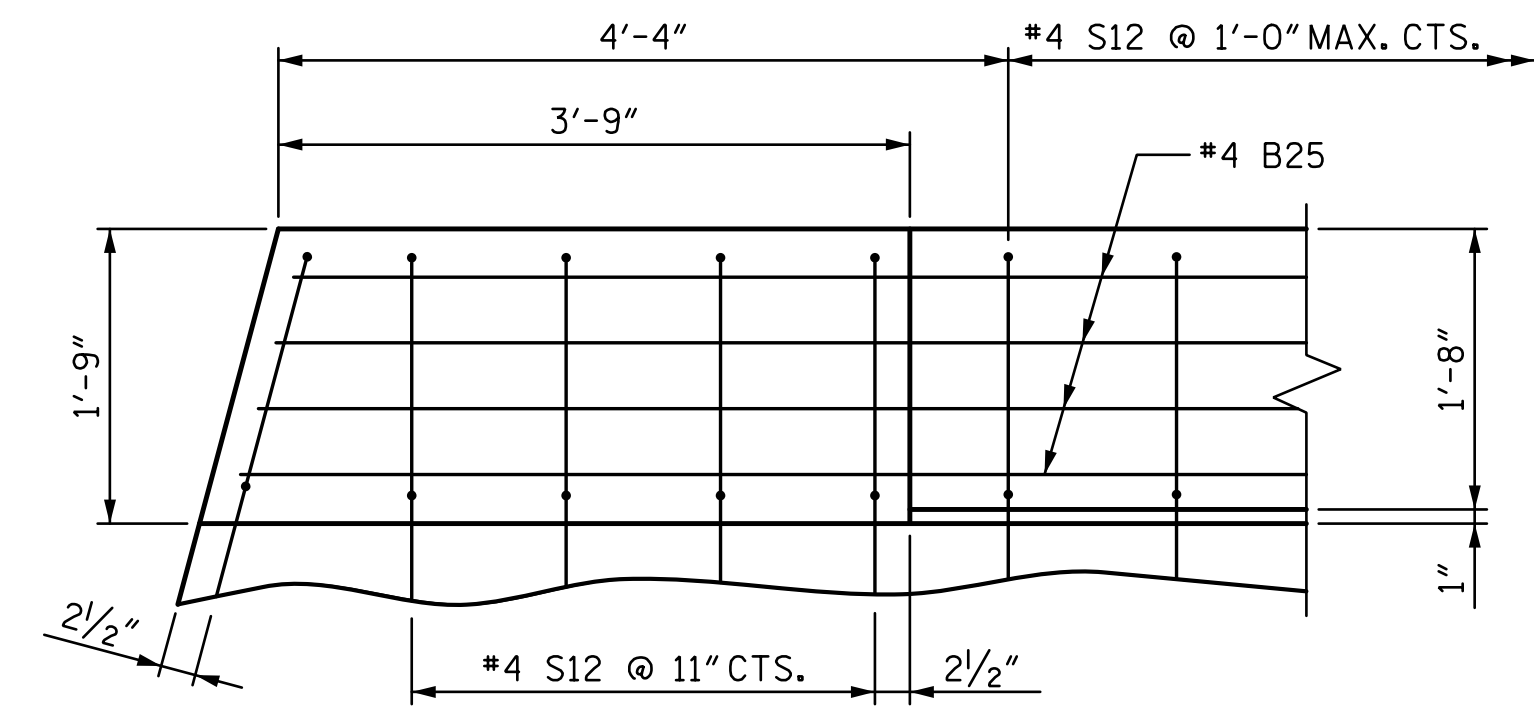

PLAN OF CURB

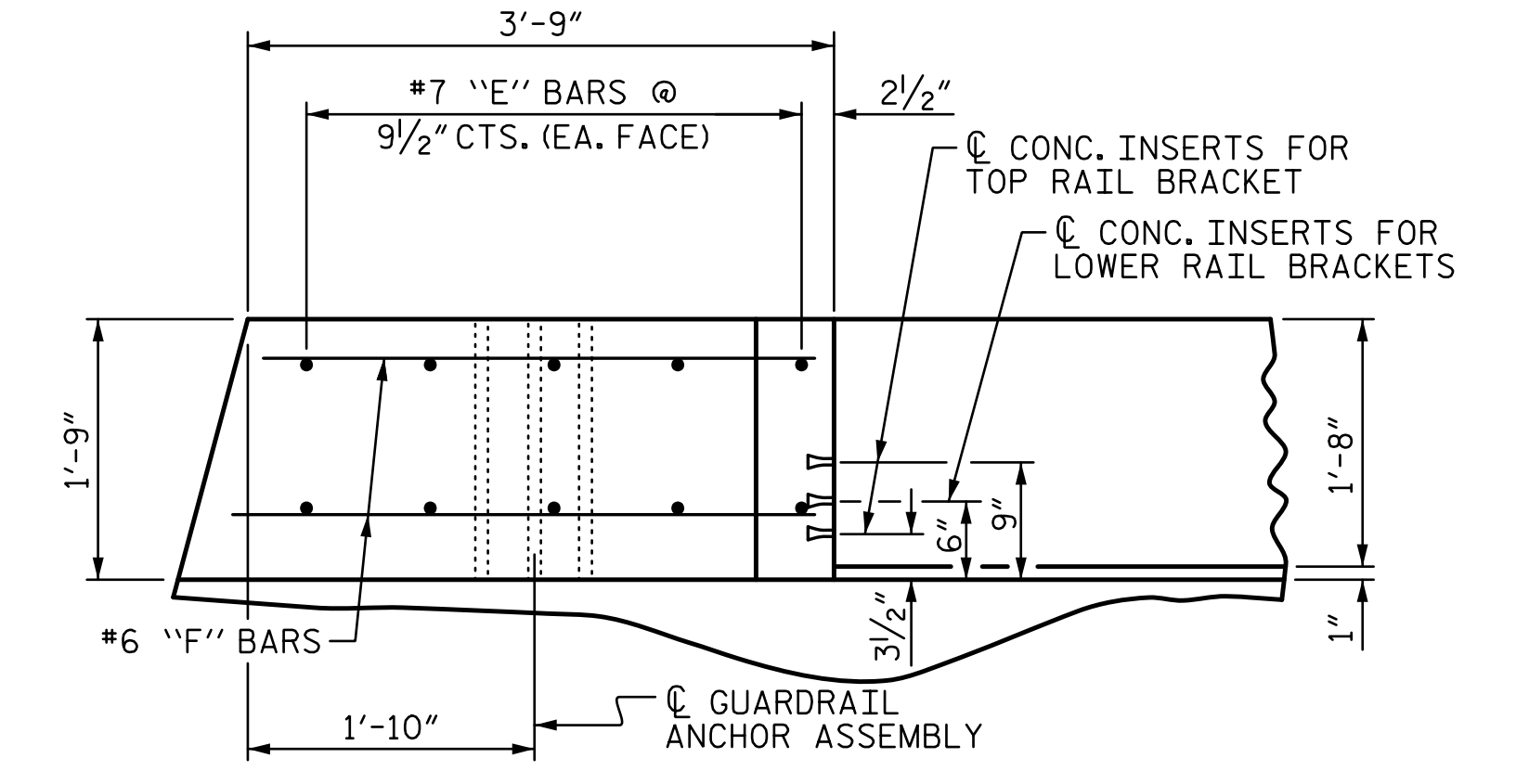

PLAN OF END POST

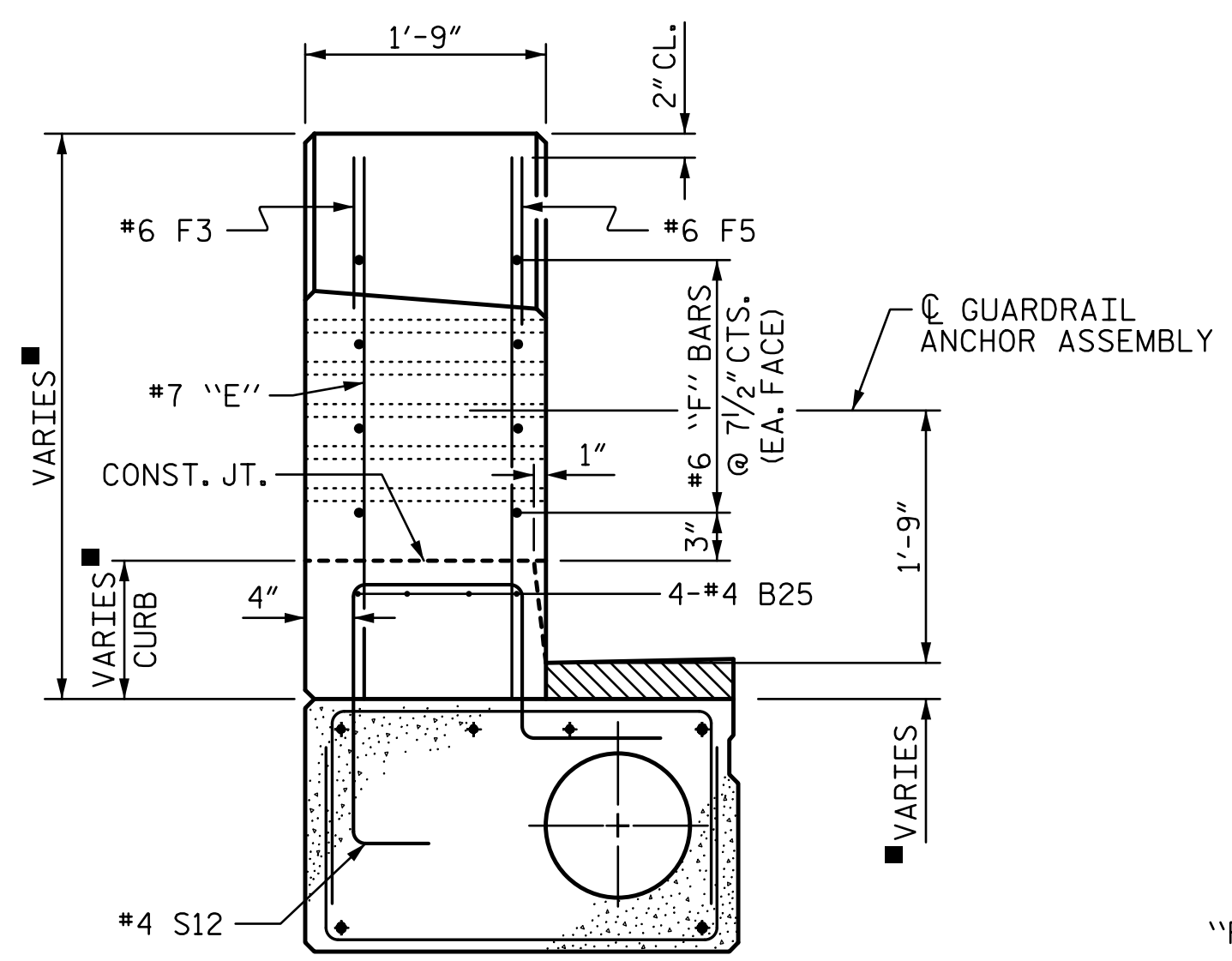

END VIEW

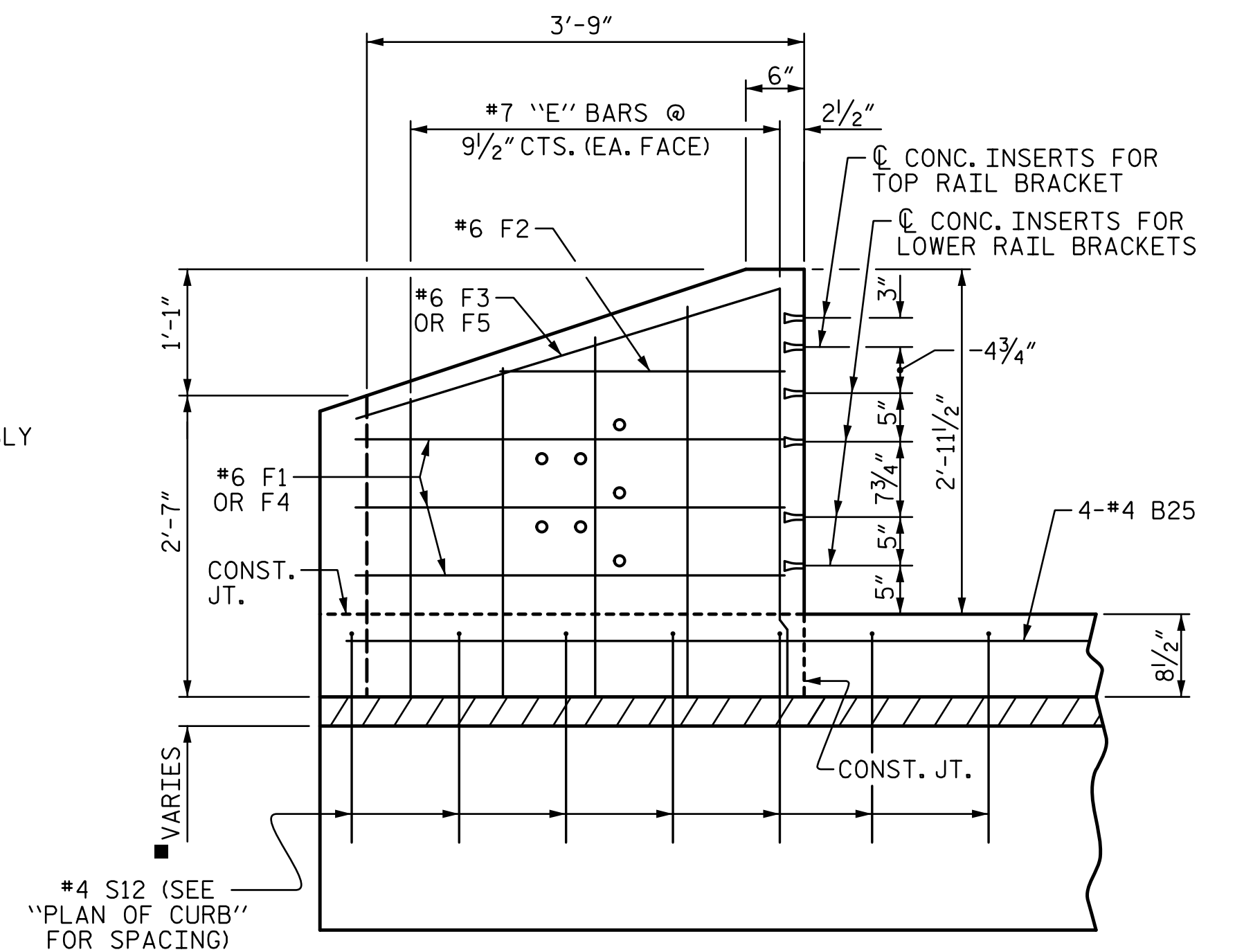

ELEVATION

CURB AND END POST FOR 42" OREGON RAIL

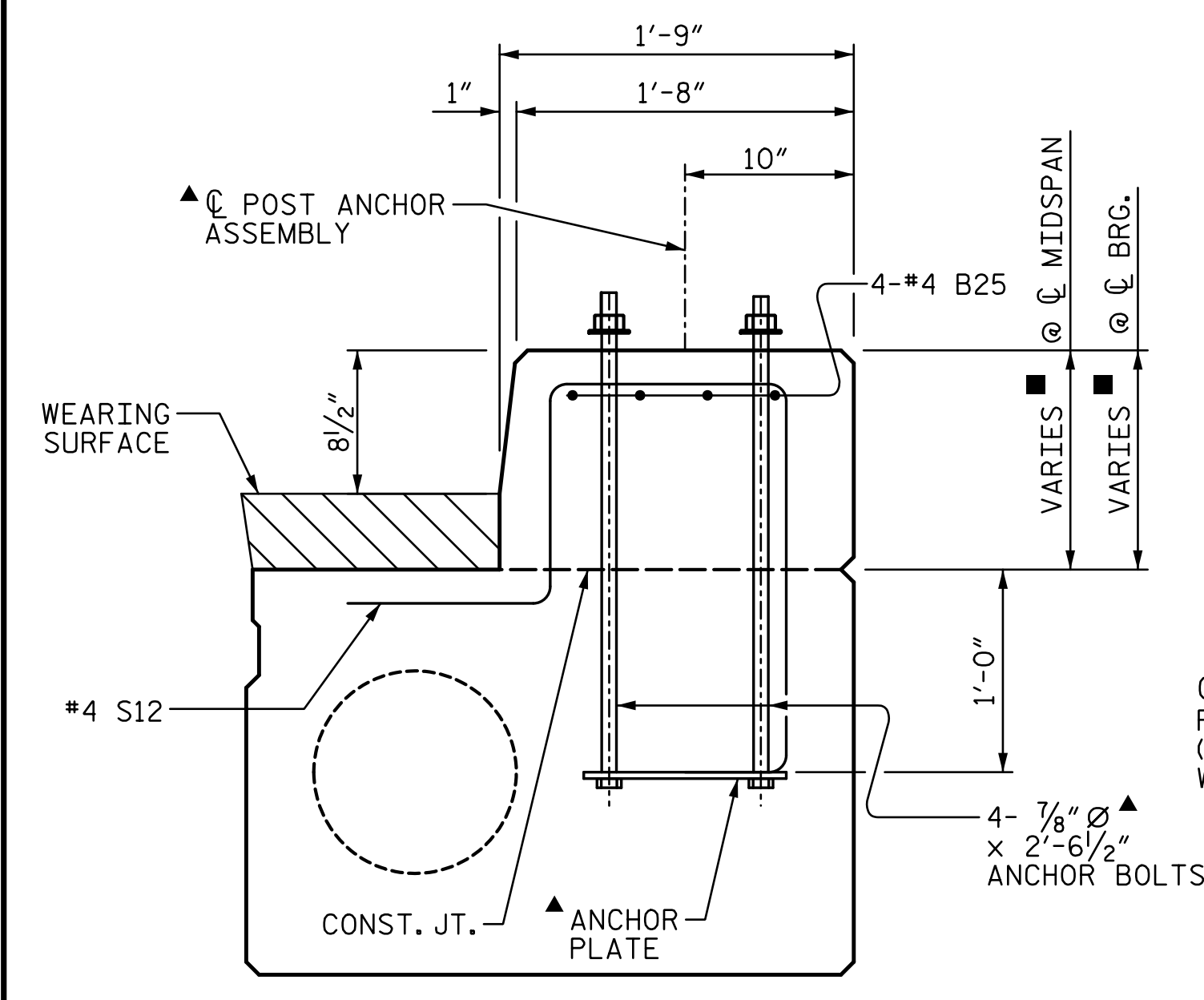

OREGON RAIL CURB SECTION

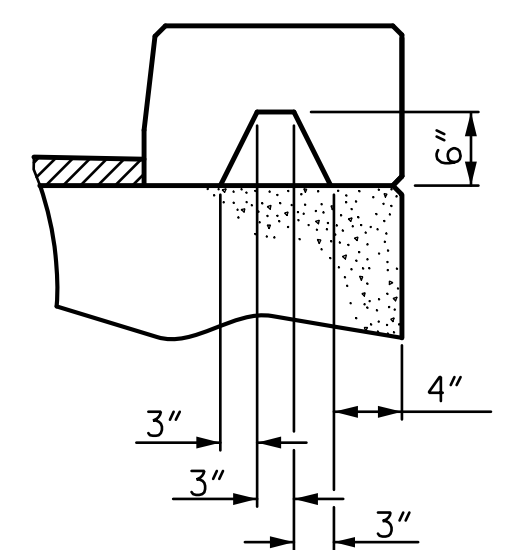

SECTION S-S
AT DAM IN OPEN JOINT
(THIS IS TO BE USED ONLY
WHEN SLIP FORM IS USED)

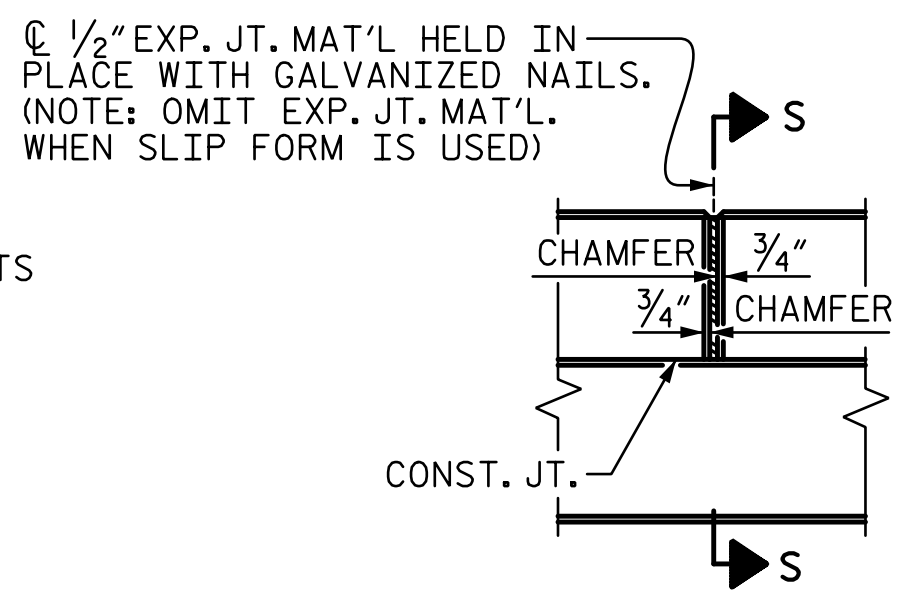

ELEVATION AT EXPANSION JOINTS

CONCRETE CURB DETAILS

FOR ADDITIONAL DETAILS AND NOTES, SEE "42" OREGON RAIL" SHEETS

3/14/2019 10:17:43 AM R:\Structures\ustation\Finals\40LITBP.10.R.133_SML_CS3_006_830162.dgn

DRAWN BY :	CL	DATE :	10-18
CHECKED BY :	LEM	DATE :	11-18
DESIGN ENGINEER OF RECORD :	LEM	DATE :	12-18

STV 100 years
STV ENGINEERS, INC.
900 West Trade St., Suite 715
Charlotte, NC 28202
NC License Number F-0991

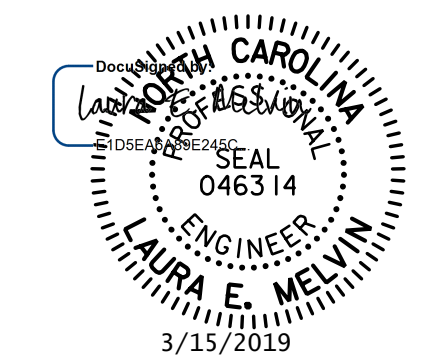

DOCUMENT NOT CONSIDERED
FINAL UNLESS ALL
SIGNATURES COMPLETED

PROJECT NO. 17BP.10.R.133
STANLY COUNTY
STATION: 15+41.00 -L-
SHEET 3 OF 4

STATE OF NORTH CAROLINA DEPARTMENT OF TRANSPORTATION RALEIGH					
3'-0" X 2'-0" PRESTRESSED CONCRETE CORED SLAB UNIT					
REVISIONS					SHEET NO.
NO.	BY:	DATE:	NO.	BY:	DATE:
1			3		
2			4		
					TOTAL SHEETS 16

BILL OF MATERIAL FOR ONE 70' CORED SLAB UNIT							
BAR	NUMBER	SIZE	TYPE	EXTERIOR UNIT		INTERIOR UNIT	
				LENGTH	WEIGHT	LENGTH	WEIGHT
B22	6	#4	STR	24'-6"	98	24'-6"	98
S10	8	#5	3	4'-10"	40	4'-10"	40
S11	148	#4	3	5'-10"	577	5'-10"	577
*S12	72	#4	1	5'-3"	253		
S13	63	#4	3	5'-10"	246		
S14	4	#4	2	5'-8"	15	5'-8"	15
S15	4	#5	3	7'-1"	30	7'-1"	30
REINFORCING STEEL				LBS.	1,006		760
* EPOXY COATED REINFORCING STEEL				LBS.	253		
7000 P.S.I. CONCRETE				CU. YDS.	13.7		12.0
0.6" Ø L.R. STRANDS				No.	28		28

CORED SLABS REQUIRED			
70' UNIT	NUMBER	LENGTH	TOTAL LENGTH
EXTERIOR C.S.	2	70'-0"	140'-0"
INTERIOR C.S.	8	70'-0"	560'-0"
TOTAL	10		700'-0"

DEAD LOAD DEFLECTION AND CAMBER		
	3'-0" x 2'-0" INTERIOR UNIT	3'-0" x 2'-0" EXTERIOR UNIT
70' CORED SLAB UNIT	0.6" Ø L.R. STRAND	0.6" Ø L.R. STRAND
CAMBER (SLAB ALONE IN PLACE)	2 1/4" ↑	1 3/4" ↑
DEFLECTION DUE TO SUPERIMPOSED DEAD LOAD**	3/4" ↓	3/4" ↓
FINAL CAMBER	1 1/2" ↑	1" ↑

** INCLUDES FUTURE WEARING SURFACE

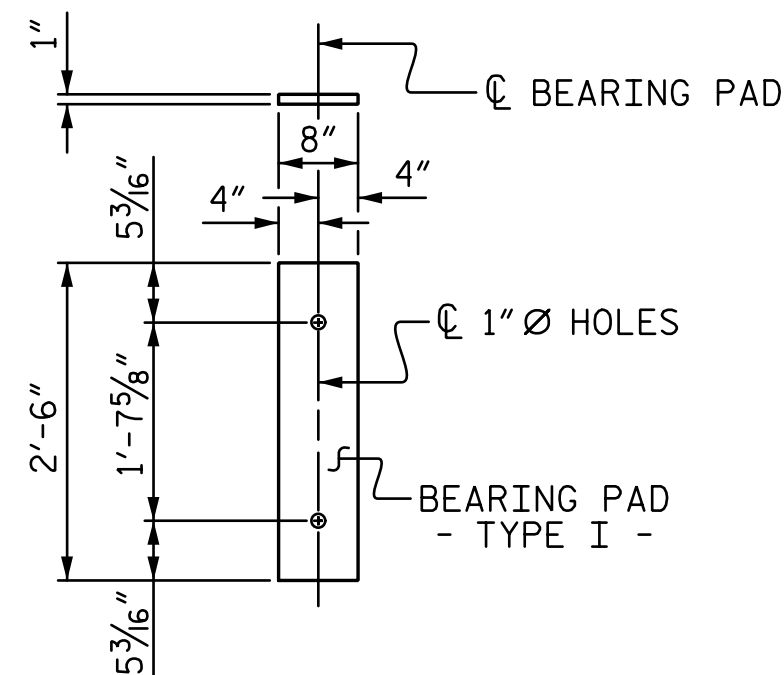

FIXED END
(TYPE I - 20 REQ'D)

ELASTOMERIC BEARING DETAILS

ELASTOMER IN ALL BEARINGS SHALL BE 60 DUROMETER HARDNESS.

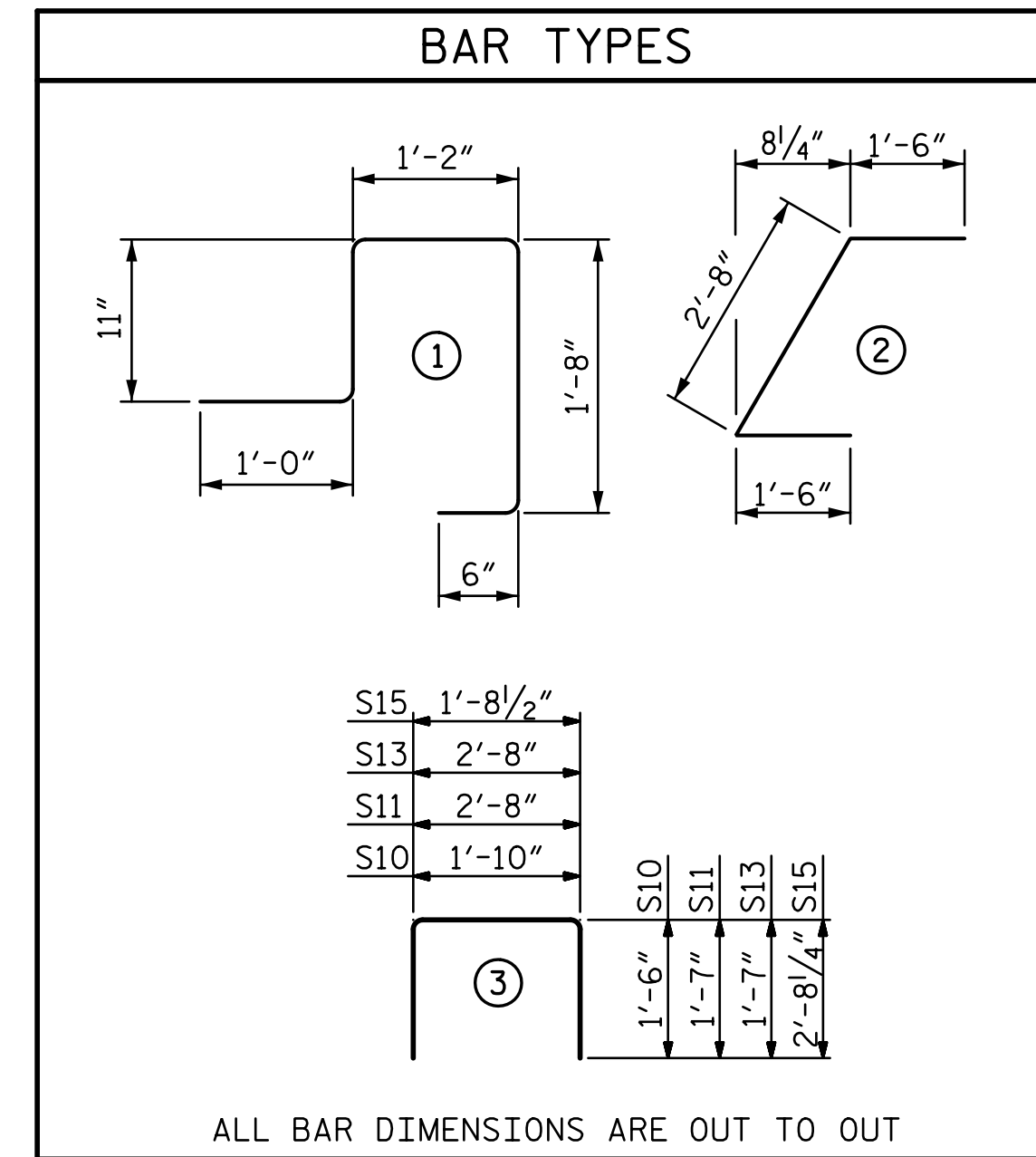

BAR TYPES

NOTES

ALL PRESTRESSING STRANDS SHALL BE 7-WIRE LOW RELAXATION GRADE 270 STRANDS AND SHALL CONFORM TO AASHTO M203 EXCEPT FOR SAMPLING REQUIREMENTS WHICH SHALL BE IN ACCORDANCE WITH THE STANDARD SPECIFICATIONS.

ALL REINFORCING STEEL CAST WITH THE CORED SLAB SECTIONS SHALL BE GRADE 60 AND SHALL BE INCLUDED IN THE UNIT PRICE BID FOR PRESTRESSED CORED SLABS.

RECESSES FOR TRANSVERSE STRANDS SHALL BE GROUTED AFTER THE TENSIONING OF THE STRANDS.

THE 2 1/2" Ø DOWEL HOLES AT FIXED ENDS OF SLAB SECTIONS SHALL BE FILLED WITH NON-SHRINK GROUT.

THE BACKER RODS SHALL CONFORM TO THE REQUIREMENTS OF TYPE M BOND BREAKER. SEE SECTION 1028 OF THE STANDARD SPECIFICATIONS.

WHEN CORED SLABS ARE CAST, AN INTERNAL HOLD-DOWN SYSTEM SHALL BE EMPLOYED TO PREVENT VOIDS FROM RISING OR MOVING SIDWAYS. AT LEAST SIX WEEKS PRIOR TO CASTING CORED SLABS, THE CONTRACTOR SHALL SUBMIT TO THE ENGINEER FOR REVIEW AND COMMENT, DETAILED DRAWINGS OF THE PROPOSED HOLD-DOWN SYSTEM. IN ADDITION TO STRUCTURAL DETAILS, LOCATION AND SPACING OF THE HOLD-DOWNS SHALL BE INDICATED.

THE TRANSFER OF LOAD FROM THE ANCHORAGES TO THE CORED SLAB UNIT SHALL BE DONE WHEN THE CONCRETE HAS REACHED A COMPRESSIVE STRENGTH OF NOT LESS THAN THE REQUIRED STRENGTH SHOWN IN THE "CONCRETE RELEASE STRENGTH" TABLE.

ALL REINFORCING STEEL IN CONCRETE CURB AND END POST SHALL BE EPOXY COATED.

PRESTRESSING STRANDS SHALL BE CUT FLUSH WITH THE CORED SLAB UNIT ENDS.

APPLY EPOXY PROTECTIVE COATING TO CORED SLAB UNIT ENDS.

GROOVED CONTRACTION JOINTS, 1/2" IN DEPTH, SHALL BE TOOLED IN ALL EXPOSED FACES OF THE CURB AND IN ACCORDANCE WITH ARTICLE 825-10(B) OF THE STANDARD SPECIFICATIONS. A CONTRACTION JOINT SHALL BE LOCATED AT EACH THIRD POINT BETWEEN CURB EXPANSION JOINTS. ONLY ONE CONTRACTION JOINT IS REQUIRED AT MIDPOINT OF CURB SEGMENTS LESS THAN 20 FEET IN LENGTH AND NO CONTRACTION JOINTS ARE REQUIRED FOR THOSE SEGMENTS LESS THAN 10 FEET IN LENGTH.

FLAME CUTTING OF THE TRANSVERSE POST-TENSIONING STRAND IS NOT ALLOWED.

MAINTAIN A SYMMETRIC TENSION FORCE BETWEEN EACH PAIR OF TRANSVERSE POST TENSIONING STRANDS IN THE DIAPHRAGM.

THE #4 S11 STIRRUPS MAY BE SHIFTED AS NECESSARY TO MAINTAIN 1" CLEAR TO THE GROUTED RECESS.

FOR GROUT FOR STRUCTURES, SEE SPECIAL PROVISIONS.

THE PERMITTED THREADED INSERTS ARE DETAILED AS AN OPTION FOR THE CONTRACTOR TO ATTACH FALSEWORK AND FORMWORK DURING CONSTRUCTION.

THE PERMITTED THREADED INSERTS IN THE EXTERIOR UNITS SHALL BE SIZED BY THE CONTRACTOR, SPACED AT 4'-0" CENTERS AND GALVANIZED IN ACCORDANCE WITH SECTION 1076 OF THE STANDARD SPECIFICATIONS. STAINLESS STEEL THREADED INSERTS MAY BE USED AS AN ALTERNATE.

THE PERMITTED THREADED INSERTS SHALL BE GROUTED BY THE CONTRACTOR IMMEDIATELY FOLLOWING REMOVAL OF THE FALSEWORK.

THE COST OF THE PERMITTED THREADED INSERTS SHALL BE INCLUDED IN THE PRICE BID FOR THE PRECAST UNITS.

THE COST OF THE METAL POST ANCHOR ASSEMBLY CAST WITH THE CORED SLAB SECTIONS SHALL BE INCLUDED IN THE PRICE BID FOR THE PRECAST UNITS.

GRADE 270 STRANDS

	0.6" Ø L.R.
AREA (SQUARE INCHES)	0.217
ULTIMATE STRENGTH (LBS. PER STRAND)	58,600
APPLIED PRESTRESS (LBS. PER STRAND)	43,950

CONCRETE RELEASE STRENGTH

UNIT	PSI
70' UNITS	5500

PROJECT NO. 17BP.10.R.133

STANLY COUNTY

STATION: 15+41.00 -L-

SHEET 4 OF 4

STATE OF NORTH CAROLINA
DEPARTMENT OF TRANSPORTATION
RALEIGH

3'-0" X 2'-0"
PRESTRESSED CONCRETE
CORED SLAB UNIT

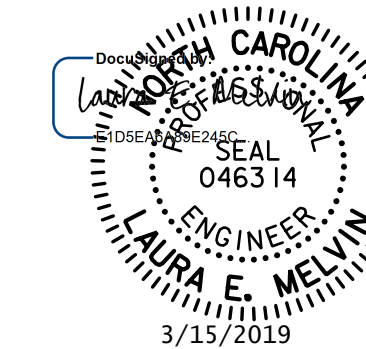

3/15/2019

STV 100 YEARS
STV ENGINEERS, INC.
900 West Trade St., Suite 715
Charlotte, NC 28202
NC License Number F-0991

DOCUMENT NOT CONSIDERED
FINAL UNLESS ALL
SIGNATURES COMPLETED

REVISIONS				SHEET NO.	
NO.	BY:	DATE:	NO.	BY:	DATE:
1			3		
2			4		

TOTAL SHEETS: 16

R:\Structures\ustation\Finals\40L013_17BP.10.R.133_SMU_CS4_007_830162.dgn

10/17/15 AM

3/14/2019

DRAWN BY : CL DATE : 10-18
CHECKED BY : LEM DATE : 11-18
DESIGN ENGINEER OF RECORD : LEM DATE : 12-18

NOTES

METAL RAIL SHALL BE GALVANIZED STEEL IN ACCORDANCE WITH THE REQUIREMENTS OF THE GENERAL NOTES AND THE FOLLOWING SPECIFICATIONS. ALUMINUM RAIL WILL NOT BE AN OPTION.

GALVANIZED STEEL RAILS

MATERIAL AND GALVANIZING ARE TO CONFORM TO THE FOLLOWING SPECIFICATIONS:

POST, POST BASES, ANCHOR PLATES, AND RAIL SPLICE TUBES: AASHTO M270 GRADE 36 STRUCTURAL STEEL-GALVANIZED TO AASHTO M111.

THE CUT ENDS OF GALVANIZED STEEL RAILING, AFTER GRINDING SMOOTH SHALL BE GIVEN TWO COATS OF ZINC RICH PAINT MEETING THE REQUIREMENTS OF FEDERAL SPECIFICATION MIL-P-26915 USAF TYPE 1, OR OF FEDERAL SPECIFICATIONS TT-P-641.

RAILS: ASTM A500 GRADE B - GALVANIZED TO AASHTO M111.

WELDED RAIL STUDS: ASTM A108-GALVANIZED TO AASHTO M111.

HIGH STRENGTH ANCHOR BOLTS SHALL CONFORM TO ASTM F1554 GRADE 105. HEAVY HEX NUTS SHALL CONFORM TO ASTM A563 DH, AND WASHERS TO ASTM F436, TYPE 1. ANCHOR BOLTS, NUTS AND WASHERS SHALL BE GALVANIZED TO AASHTO M111.

GENERAL NOTES

RAILING SHALL BE CONTINUOUS FROM END POST TO END POST OF BRIDGE. EACH JOINT IN RAIL LENGTH SHALL BE SPLICED AS DETAILED. PANEL LENGTHS OF RAIL SHALL BE ATTACHED TO A MINIMUM OF THREE POSTS.

FOR END OF RAIL TO CLEAR FACE OF CONCRETE END POST DIMENSION, SEE "RAIL POST SPACINGS AND END OF RAIL DETAILS" SHEET.

CERTIFIED MILL REPORTS ARE REQUIRED FOR RAILS AND POSTS. SHOP INSPECTION IS NOT REQUIRED.

METAL RAIL POSTS SHALL BE SET NORMAL TO CURB GRADE.

CURVED RAIL USAGE: WHERE RAILS ARE TO BE USED ON BRIDGES ON HORIZONTAL AND/OR VERTICAL CURVATURE THE CONTRACTOR MAY, AT HIS OPTION, HAVE THE REQUIRED CURVATURE IN THE RAIL FORMED IN THE SHOP OR IN THE FIELD. IN EITHER EVENT, THE RAIL SHALL CONFORM WITHOUT BUCKLING OR KINKING TO THE REQUIRED CURVATURE IN A UNIFORM MANNER ACCEPTABLE TO THE ENGINEER.

TO INSURE FUTURE IDENTIFICATION OF THE FABRICATOR, A PERMANENT IDENTIFYING MARK SHALL BE PLACED ON EACH POST. THE METHOD OF MARKING AND LOCATION SHALL BE SUCH THAT IT DOES NOT DETRACT FROM THE APPEARANCE OF THE POST, BUT REMAINS VISIBLE AFTER RAIL PLACEMENT.

SHIMS SHALL BE USED AS NECESSARY FOR POST ALIGNMENT.

GROOVED CONTRACTION JOINTS, 1/2" IN DEPTH, SHALL BE TOOLED IN ALL EXPOSED FACES OF THE CURB AND IN ACCORDANCE WITH ARTICLE 825-10(B) OF THE STANDARD SPECIFICATIONS. A CONTRACTION JOINT SHALL BE LOCATED AT EACH THIRD POINT BETWEEN CURB EXPANSION JOINTS. ONLY ONE CONTRACTION JOINT IS REQUIRED AT MIDPOINT OF CURB SEGMENTS LESS THAN 20 FEET IN LENGTH AND NO CONTRACTION JOINTS ARE REQUIRED FOR THOSE SEGMENTS LESS THAN 10 FEET IN LENGTH.

THE RAIL SECTIONS SHALL BE ATTACHED TO THE POSTS BY TWO THREADED 3/4" Ø WELDED STUDS, PLATE WASHERS, LOCKWASHERS, AND NUTS.

FOR 42" OREGON RAIL, SEE THE STANDARD SPECIFICATIONS.

TOTAL LENGTH OF METAL RAIL 125 LIN. FT.

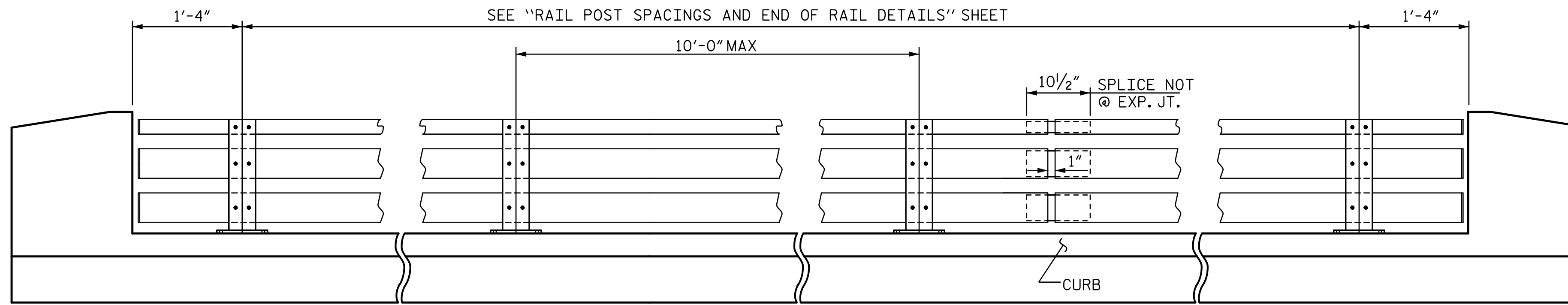

ELEVATION

NOTE: FOR ATTACHMENT OF METAL RAIL TO END POST, SEE "RAIL POST SPACINGS AND END OF RAIL DETAILS" SHEET

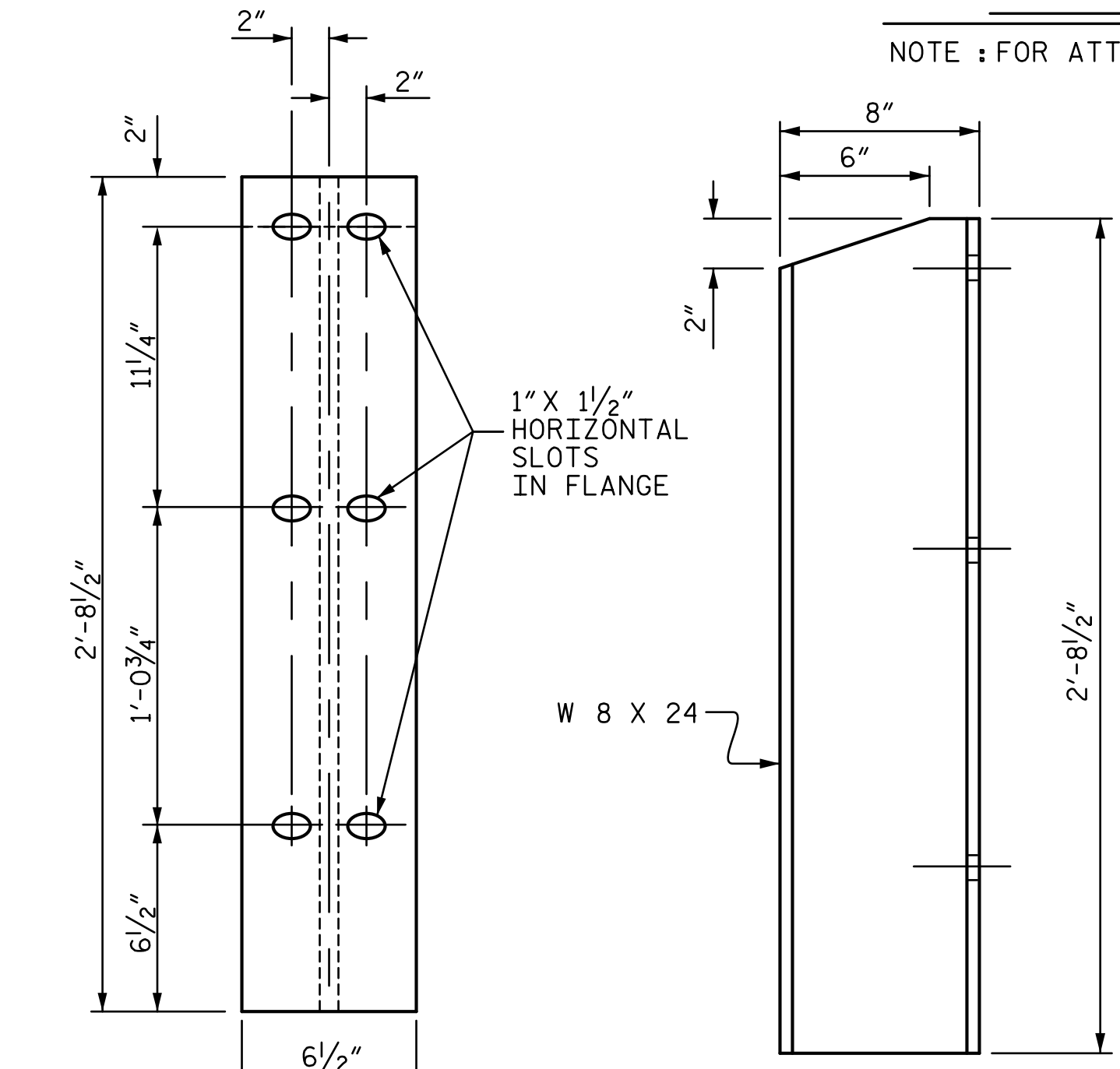

FRONT ELEVATION SIDE ELEVATION
DETAILS OF POST

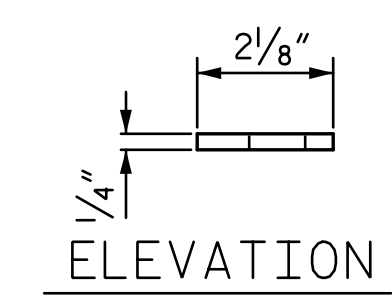

ELEVATION

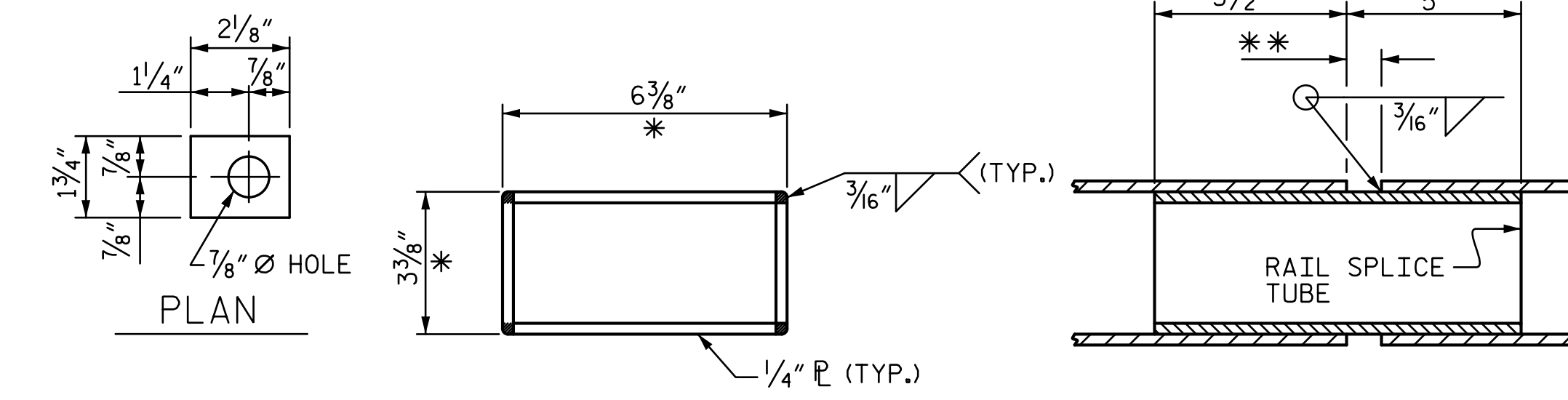
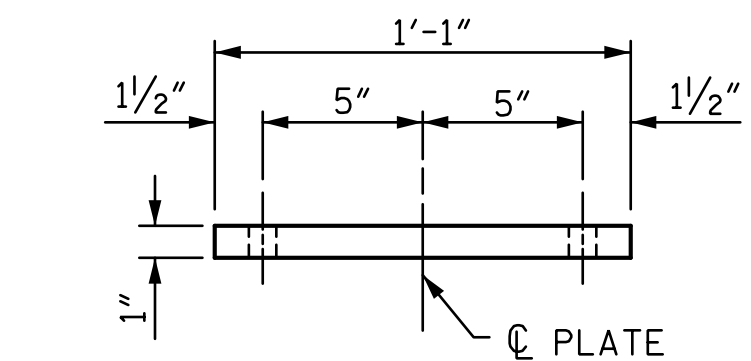
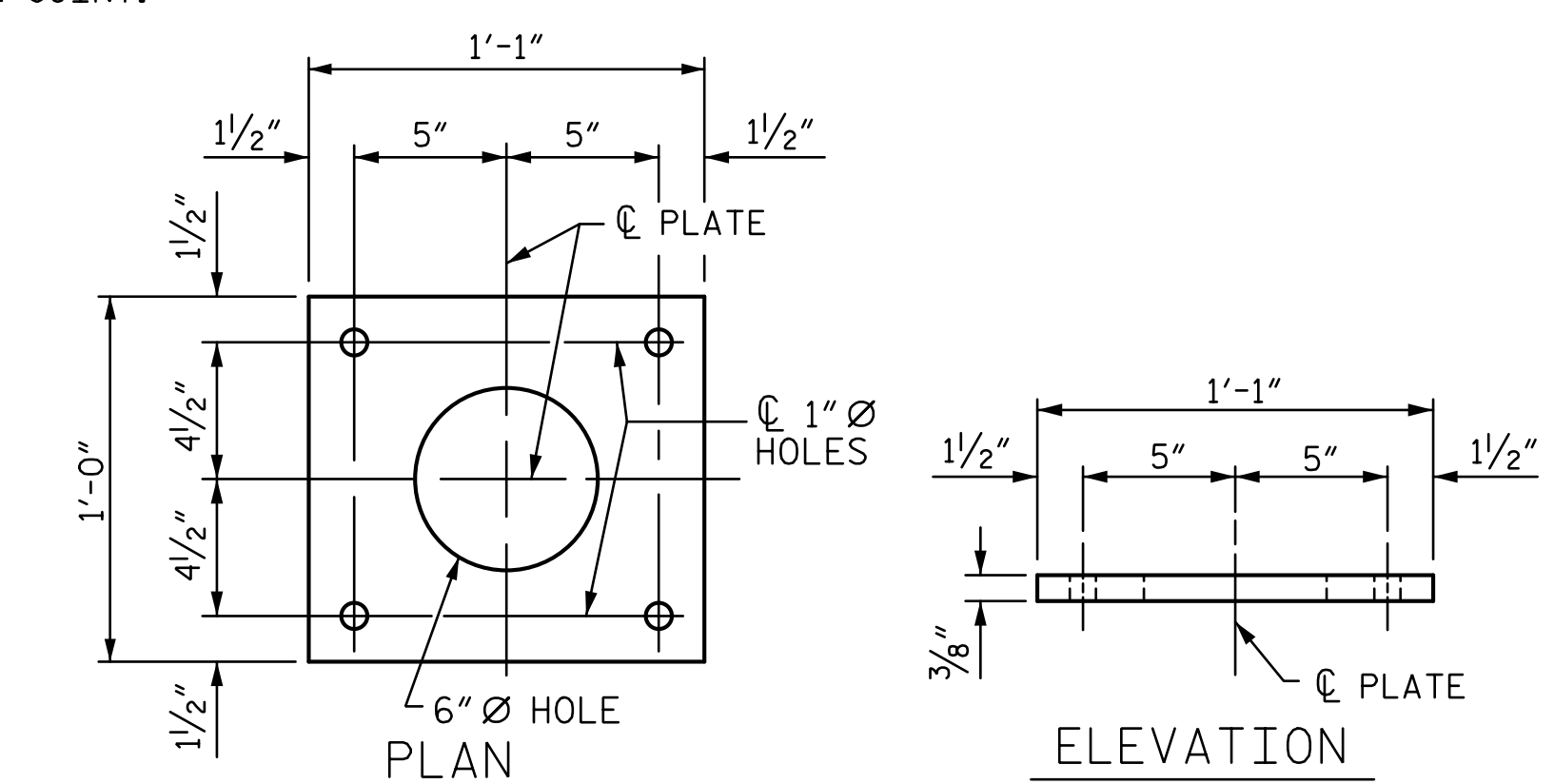

PLATE WASHER RAIL SPLICE DETAILS

* - DIMENSION AFTER GRINDING RADIUS ON CORNERS TO MATCH INSIDE OF METAL RAIL. GRIND ALL EDGES PRIOR TO GALVANIZING TO ASSURE FIT.
** - 1" FOR SPLICE NOT AT EXPANSION JOINT.



FRONT ELEVATION



ANCHOR PLATE DETAILS

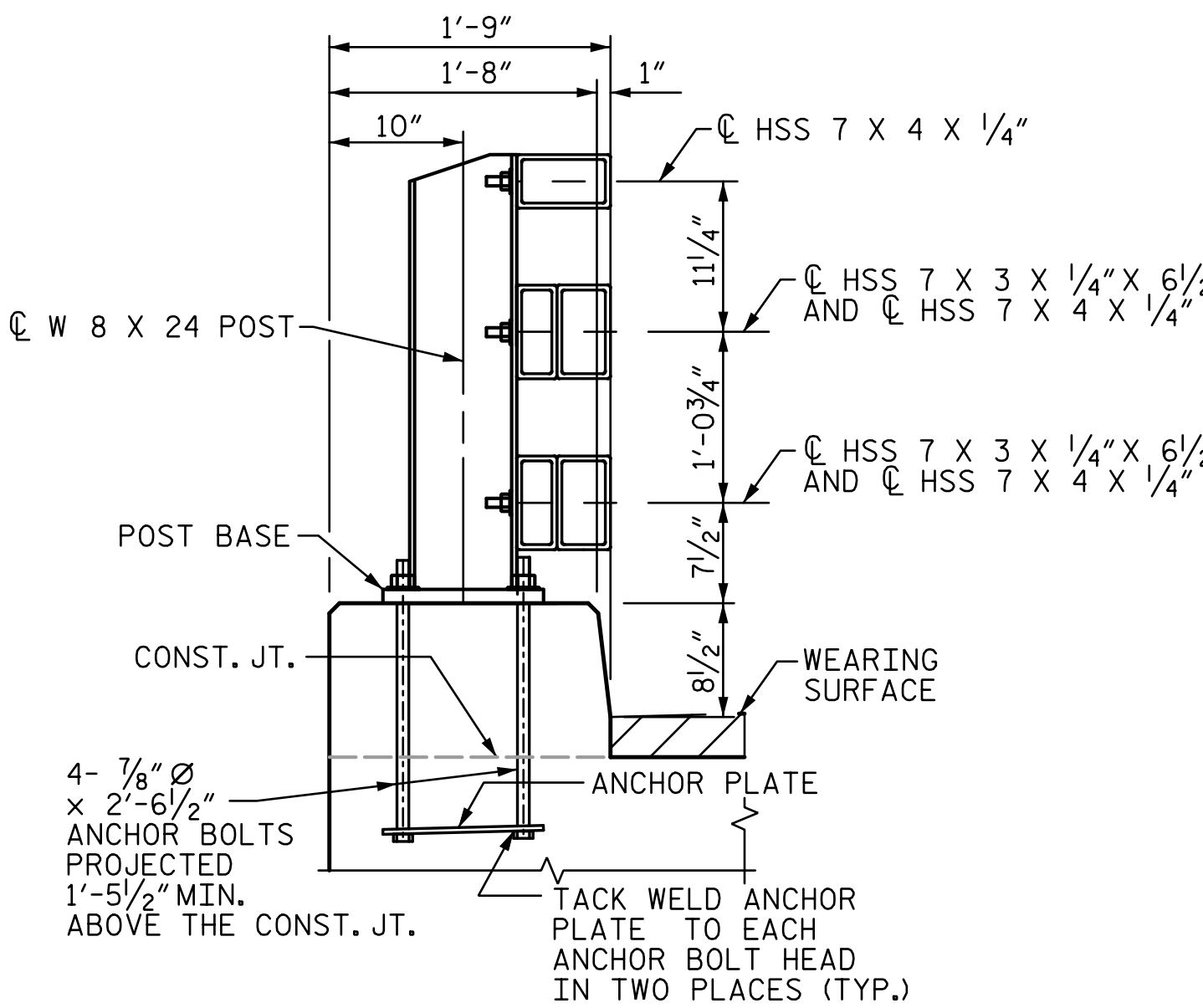

SECTION THRU RAIL

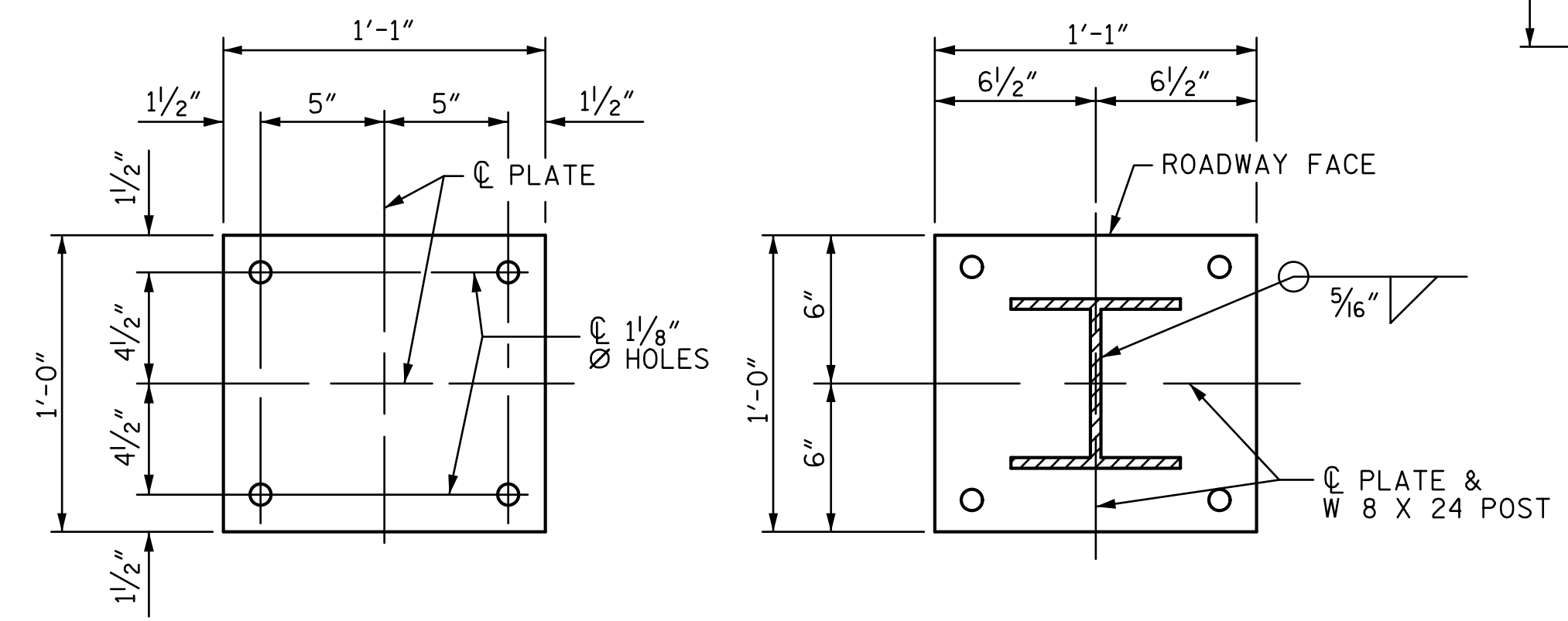

PLAN POST ATTACHMENT DETAIL

POST BASE DETAILS

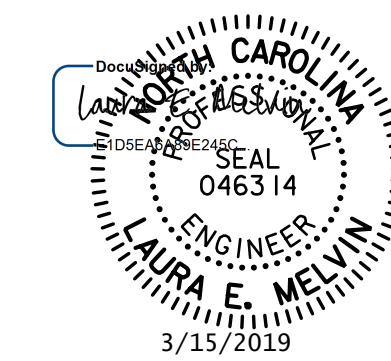

STV ENGINEERS, INC.
900 West Trade St., Suite 715
Charlotte, NC 28202
NC License Number F-0991

DOCUMENT NOT CONSIDERED FINAL UNLESS ALL SIGNATURES COMPLETED

PROJECT NO. 17BP.10.R.133
STANLY COUNTY
STATION: 15+41.00 -L-

SHEET 1 OF 2
STATE OF NORTH CAROLINA
DEPARTMENT OF TRANSPORTATION
RALEIGH
STANDARD
42" OREGON RAIL

REVISIONS				SHEET NO.
NO.	BY:	DATE:	NO.	DATE:
1			3	
2			4	

S-8
TOTAL SHEETS 16

R:\Structures\ustation\Finals\40L015_17BP.10.R.133_SMU_ORI_008_830162.dgn 3/14/2019 10:17:47 AM MeivInLE

ASSEMBLED BY : CL	DATE : 10-18
CHECKED BY : LEM	DATE : 11-18
DESIGN ENGINEER OF RECORD : LEM	DATE : 12-18
DRAWN BY : RWW 7/14	REV. 12/17 MAA/THC
CHECKED BY : TMG 7/14	

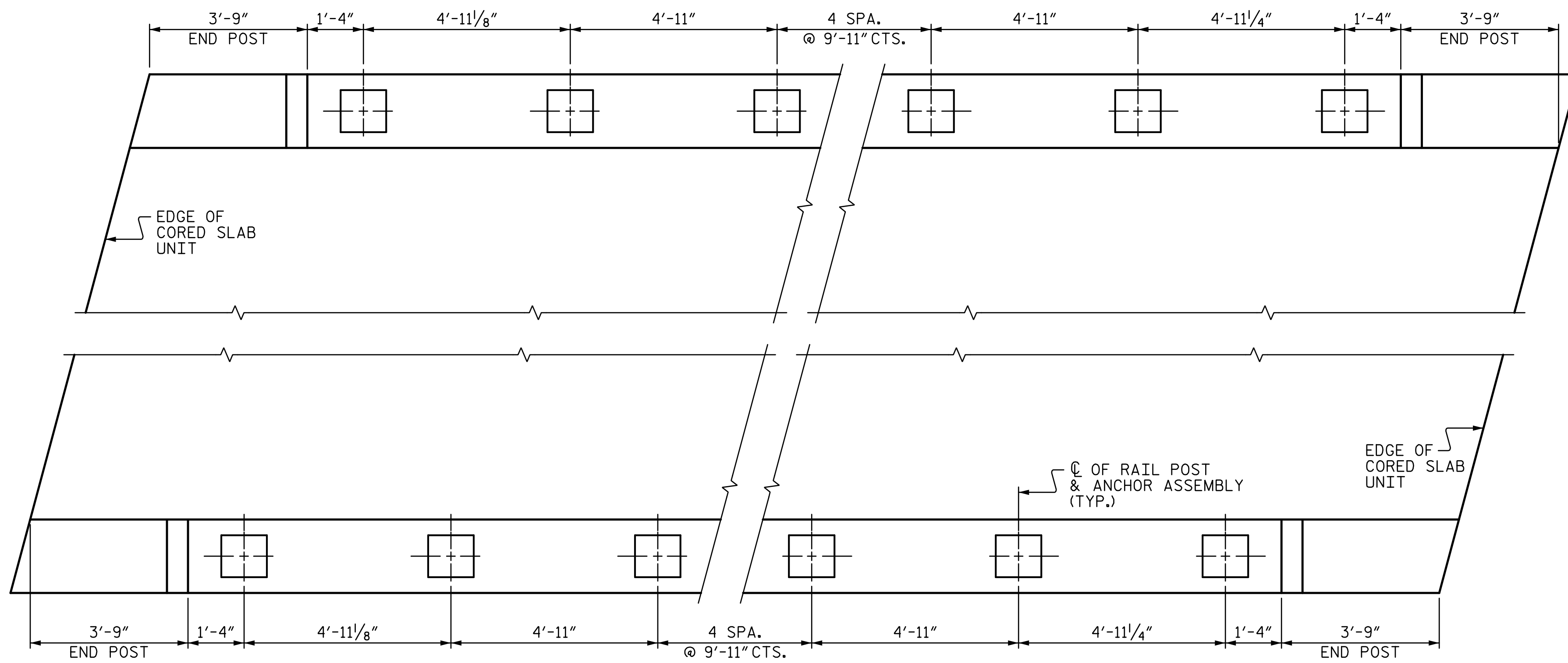

PLAN OF RAIL POST SPACINGS

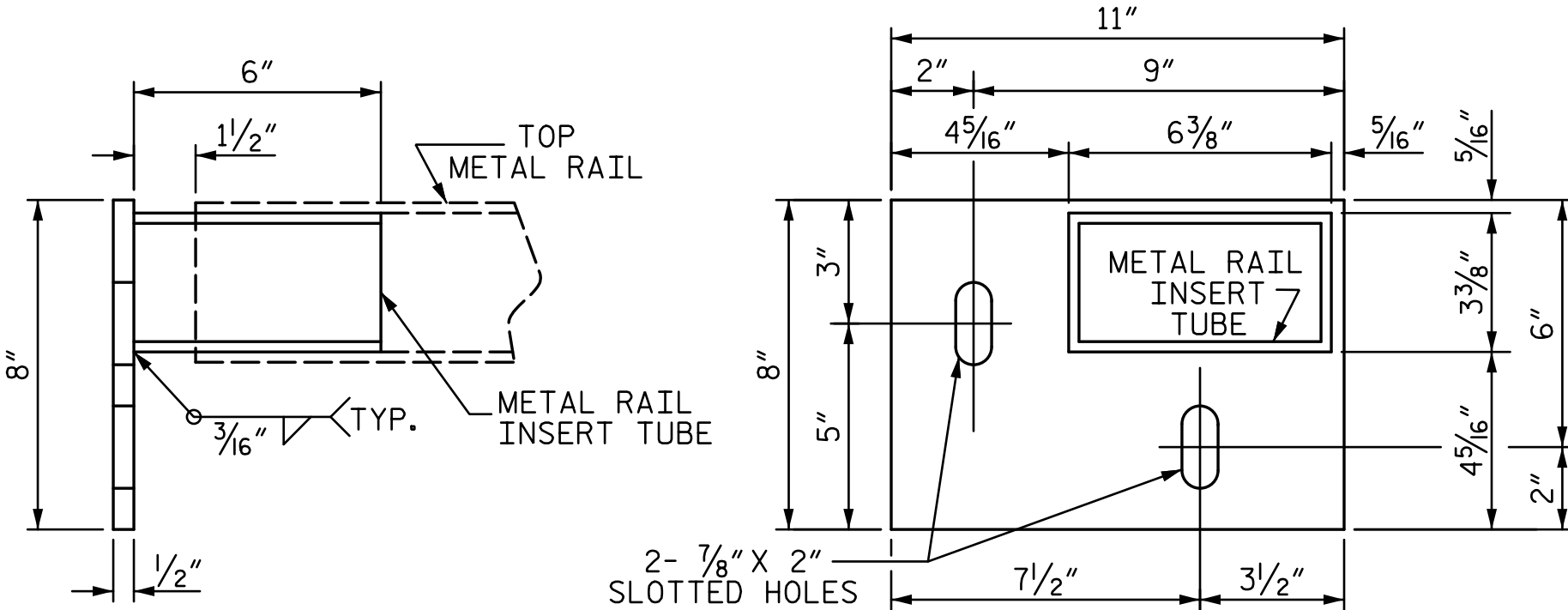
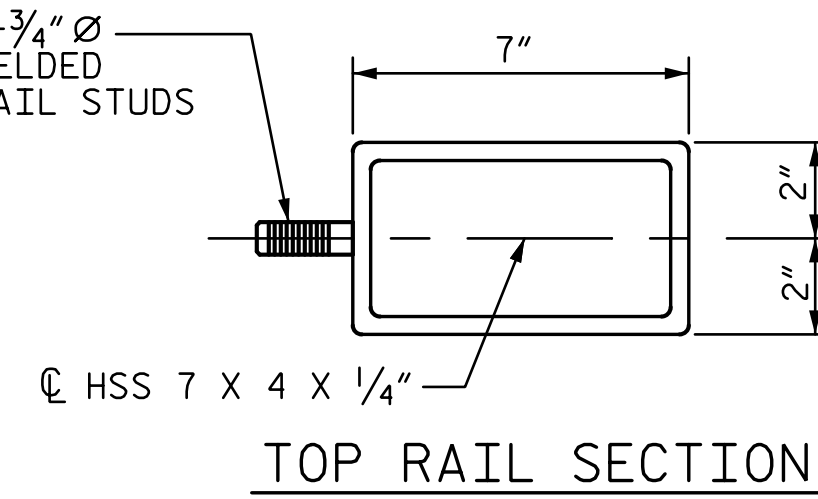
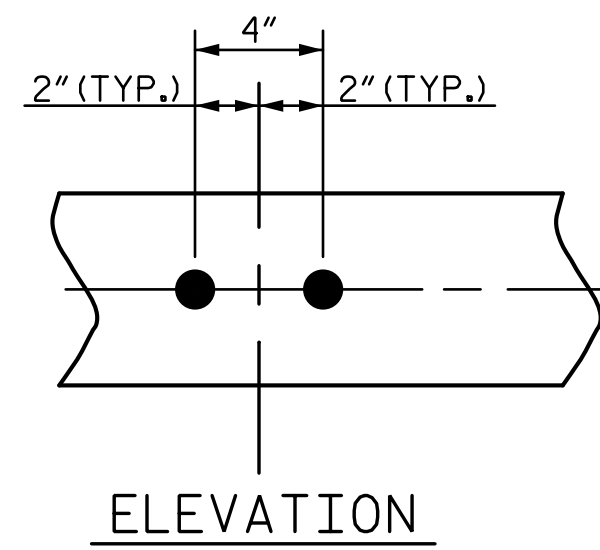

TOP METAL RAIL ATTACHMENT BRACKET

THE METAL RAIL INSERT TUBE SHALL BE FABRICATED FROM 1/4" PLATES.

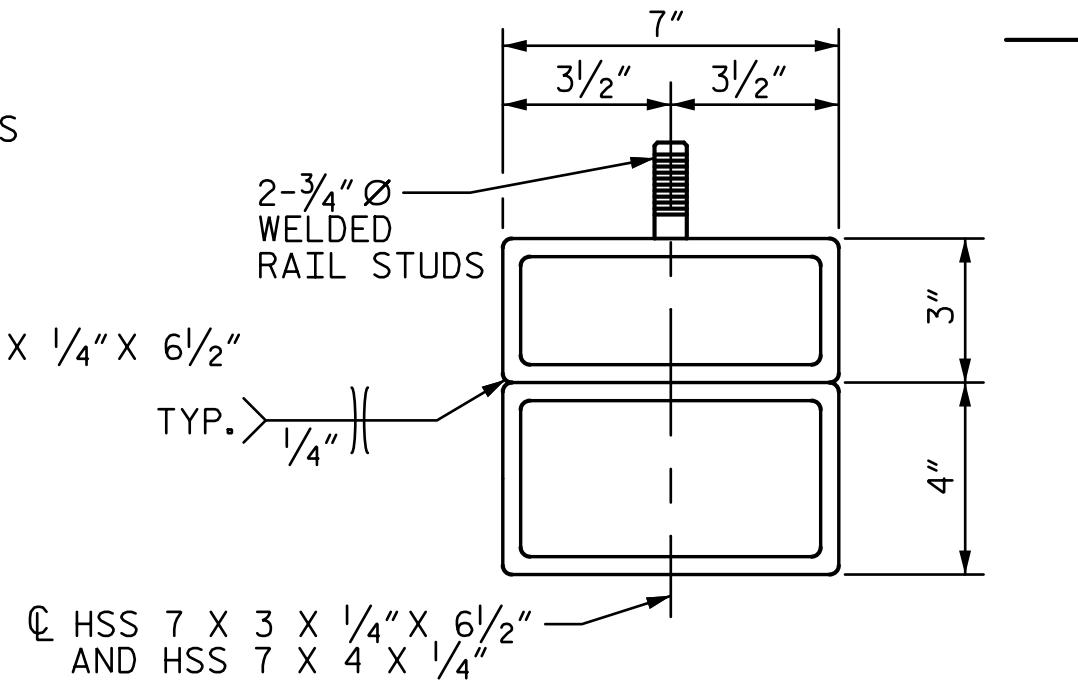
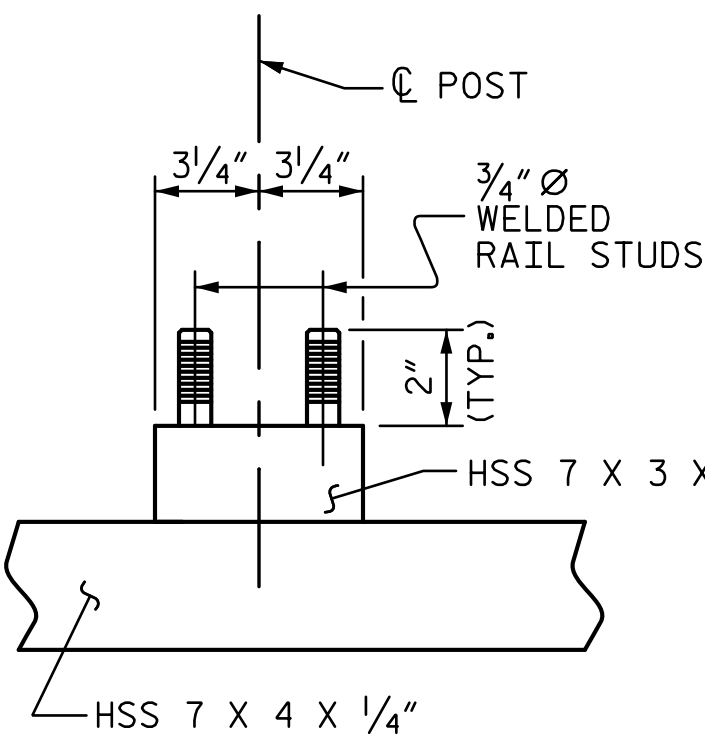

RAIL STUD DETAILS

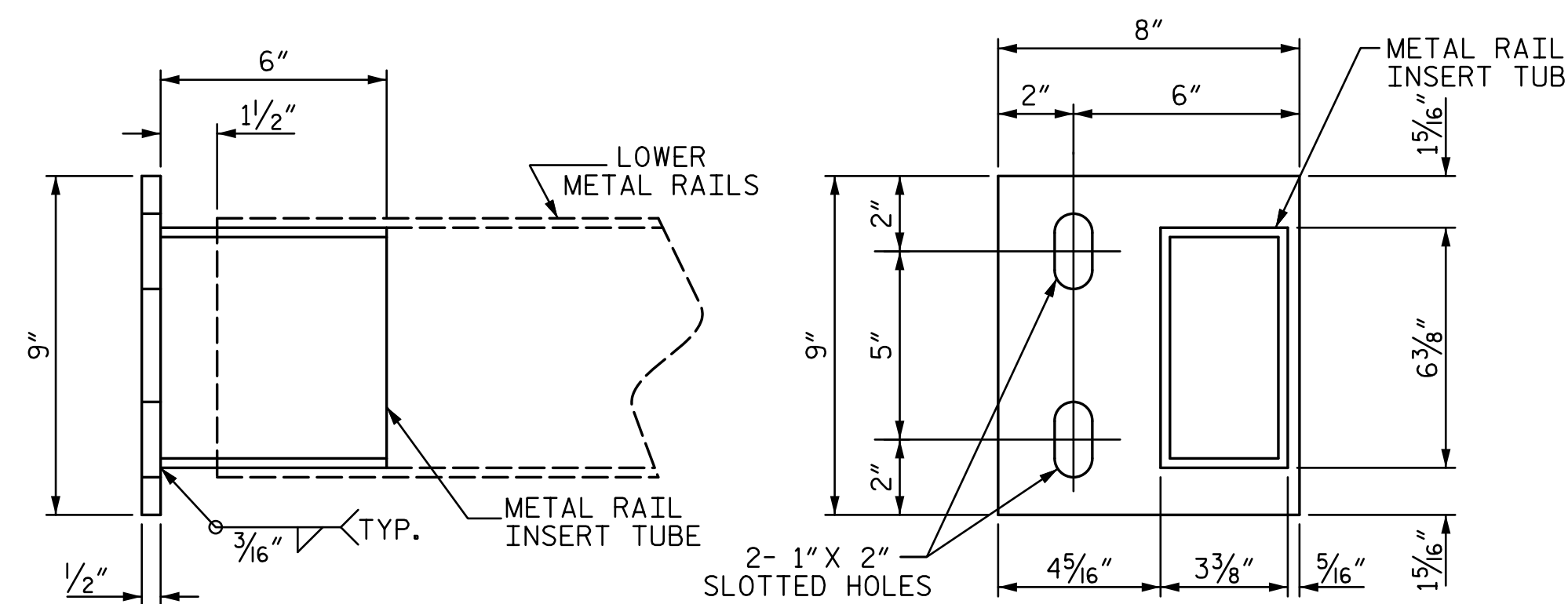

LOWER METAL RAILS ATTACHMENT BRACKET

THE METAL RAIL INSERT TUBE SHALL BE FABRICATED FROM 1/4" PLATES.

NOTES

STRUCTURAL CONCRETE INSERT

EACH STRUCTURAL CONCRETE INSERT ASSEMBLY SHALL CONSIST OF THE FOLLOWING COMPONENTS:

- A. FERRULE SHALL BE MADE FROM STEEL MEETING THE REQUIREMENTS OF AASHTO M169, GRADE 12L14 AND SHALL HAVE A MINIMUM LENGTH OF 1 1/2".
- B. 1 - 3/4" Ø X 1 5/8" BOLT WITH WASHER. BOLT SHALL CONFORM TO THE REQUIREMENTS OF ASTM A307. BOLT AND WASHER SHALL BE GALVANIZED. (AT THE CONTRACTOR'S OPTION, STAINLESS STEEL BOLT AND WASHER MAY BE USED AS AN ALTERNATE FOR THE 3/4" Ø X 1 5/8" GALVANIZED BOLT AND WASHER. THEY SHALL CONFORM TO OR EXCEED THE MECHANICAL REQUIREMENTS OF ASTM A307. THE USE OF THIS ALTERNATE SHALL BE APPROVED BY THE ENGINEER.)
- C. WIRE STRUT SHOWN IN THE STRUCTURAL CONCRETE INSERT DETAIL IS THE MINIMUM ALLOWABLE SIZE AND SHALL HAVE A MINIMUM TENSILE STRENGTH OF 100,000 PSI. AS AN OPTION, A 1/16" Ø WIRE STRUT WITH A MINIMUM TENSILE STRENGTH OF 90,000 PSI IS ACCEPTABLE.

NOTES

METAL RAIL TO END POST CONNECTION

EACH METAL RAIL TO END POST CONNECTION SHALL CONSIST OF THE FOLLOWING COMPONENTS:

- A. 1/2" METAL BRACKET PLATE AND 1/4" METAL RAIL INSERT TUBE SHALL CONFORM TO AASHTO M270 GRADE 36 AND SHALL BE GALVANIZED AFTER FABRICATION TO AASHTO M111.
- B. 3/4" STRUCTURAL CONCRETE INSERTS SHALL HAVE A WORKING LOAD SHEAR CAPACITY OF 4800 LBS. THE FERRULES SHALL ENGAGE A 3/4" Ø X 1 5/8" BOLT WITH 2" O.D. WASHER IN PLACE. THE 3/4" Ø X 1 5/8" BOLT SHALL HAVE N. C. THREADS.

THE 3/4" STRUCTURAL CONCRETE INSERTS WITH BOLTS SHALL BE ASSEMBLED IN THE SHOP.

THE COST OF THE 3/4" STRUCTURAL CONCRETE INSERT, THE 1/2" BRACKET PLATES, AND THE RAIL INSERT TUBES COMPLETE IN PLACE SHALL BE INCLUDED IN THE VARIOUS PAY ITEMS.

THE CONTRACTOR, AT HIS OPTION, MAY USE AN ADHESIVE BONDING SYSTEM IN LIEU OF THE STRUCTURAL CONCRETE INSERT EMBEDDED IN THE END POST. IF THE ADHESIVE BONDING SYSTEM IS USED, THE 3/4" Ø X 1 5/8" BOLTS WITH WASHERS SHALL BE REPLACED WITH 3/4" Ø X 6 1/2" BOLTS AND 2" O.D. WASHERS. ALL SPECIFICATIONS THAT APPLY TO THE 3/4" Ø X 1 5/8" BOLTS SHALL APPLY TO THE 3/4" Ø X 6 1/2" BOLTS. FIELD TESTING OF THE ADHESIVE BONDING SYSTEM IS NOT REQUIRED.

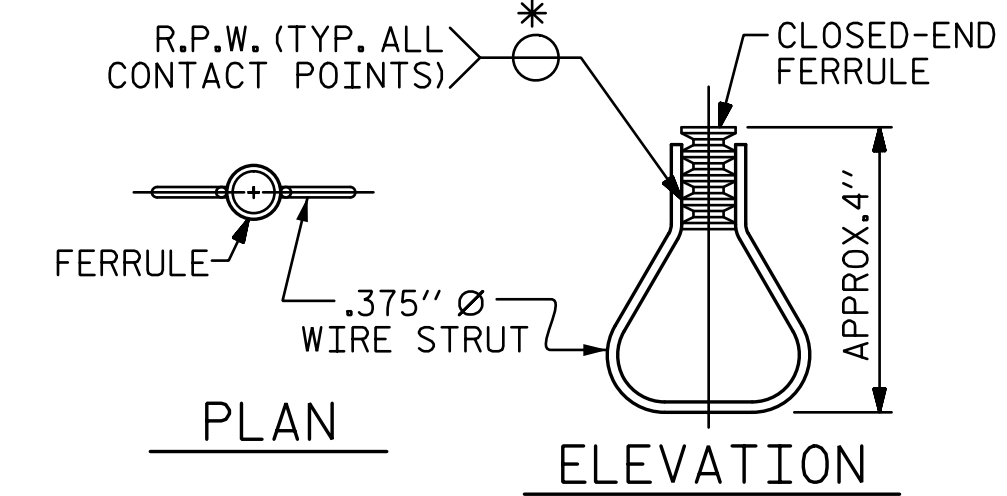
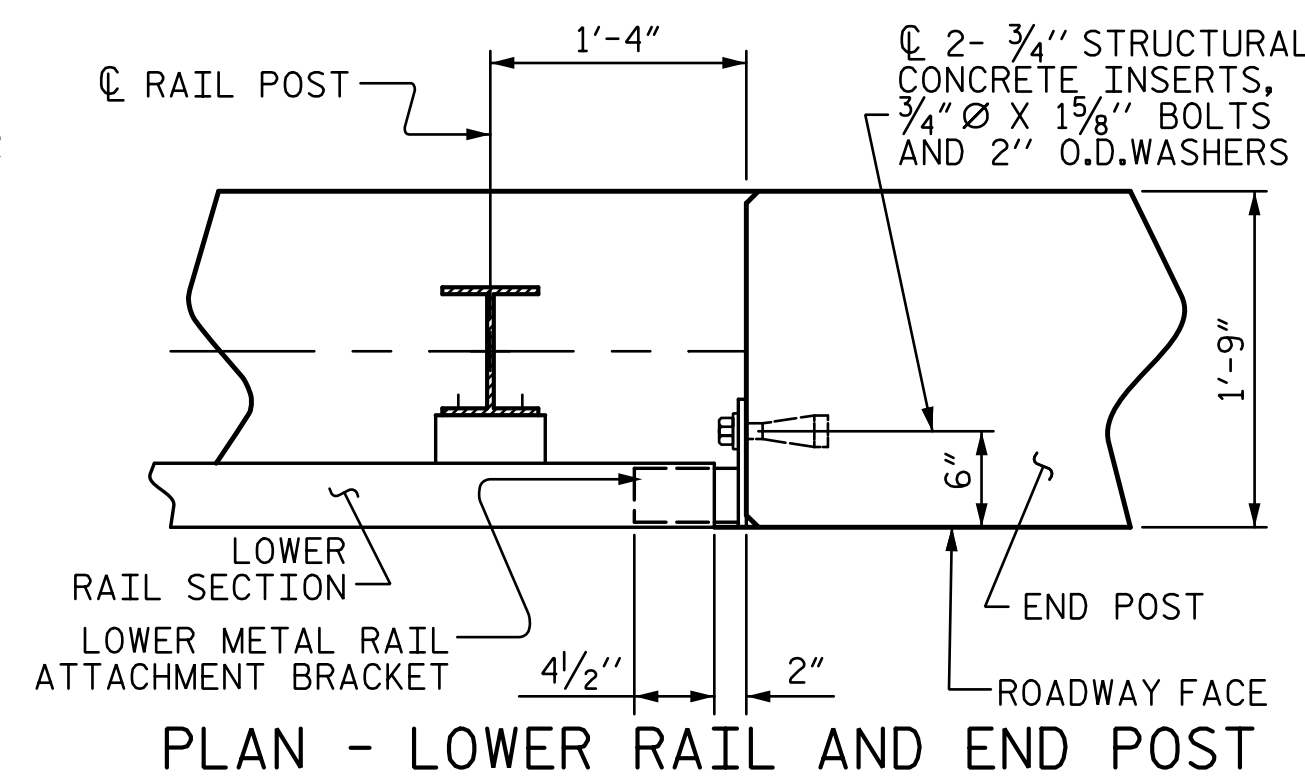
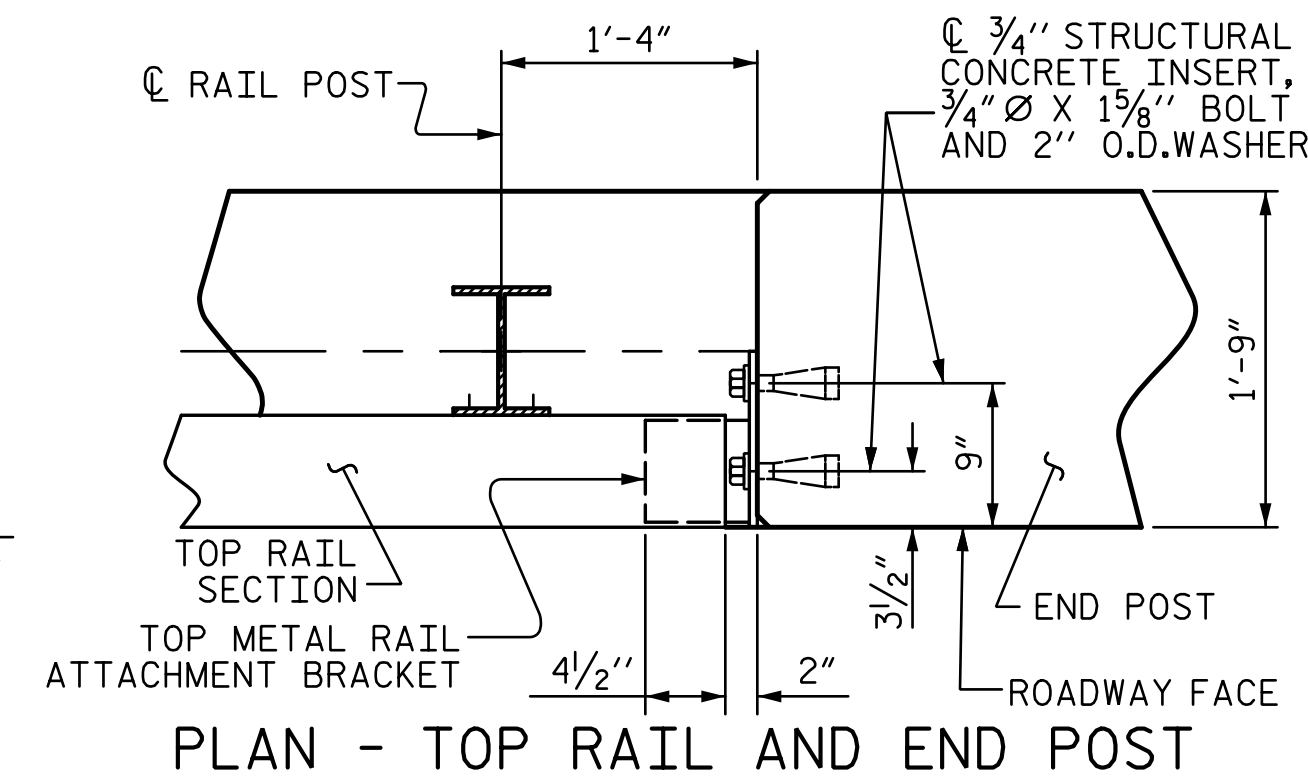

STRUCTURAL CONCRETE INSERT

* EACH WELDED ATTACHMENT OF WIRE TO FERRULE SHALL DEVELOP THE TENSILE STRENGTH OF THE WIRE.

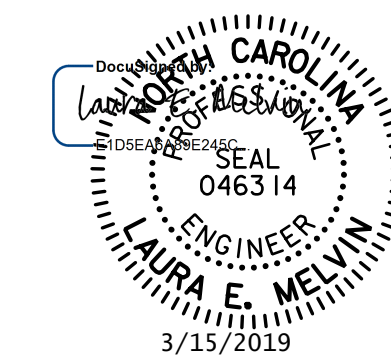

STV 100 YEARS STV ENGINEERS, INC. 900 West Trade St., Suite 715 Charlotte, NC 28202 NC License Number F-0991

DOCUMENT NOT CONSIDERED FINAL UNLESS ALL SIGNATURES COMPLETED

PROJECT NO. 17BP.10.R.133
 STANLY COUNTY
 STATION: 15+41.00 -L-

SHEET 2 OF 2

STATE OF NORTH CAROLINA
 DEPARTMENT OF TRANSPORTATION
 RALEIGH
 STANDARD
 RAIL POST SPACINGS
 AND
 END OF RAIL DETAILS
 FOR 42" OREGON RAIL

REVISIONS				SHEET NO.
NO.	BY:	DATE:	NO.	DATE:
1			3	
2			4	

S-9
TOTAL SHEETS 16

R:\Structures\ustation\Finals\401017BP.10.R.133_SMU_OR2_009_830162.dgn 3/14/2019 10:48 AM Meivincle

ASSEMBLED BY : CL	DATE : 10-18
CHECKED BY : LEM	DATE : 11-18
DESIGN ENGINEER OF RECORD : LEM	DATE : 12-18
DRAWN BY : RWW 7/14	REV. 12/17 MAA/THC
CHECKED BY : TMG 7/14	

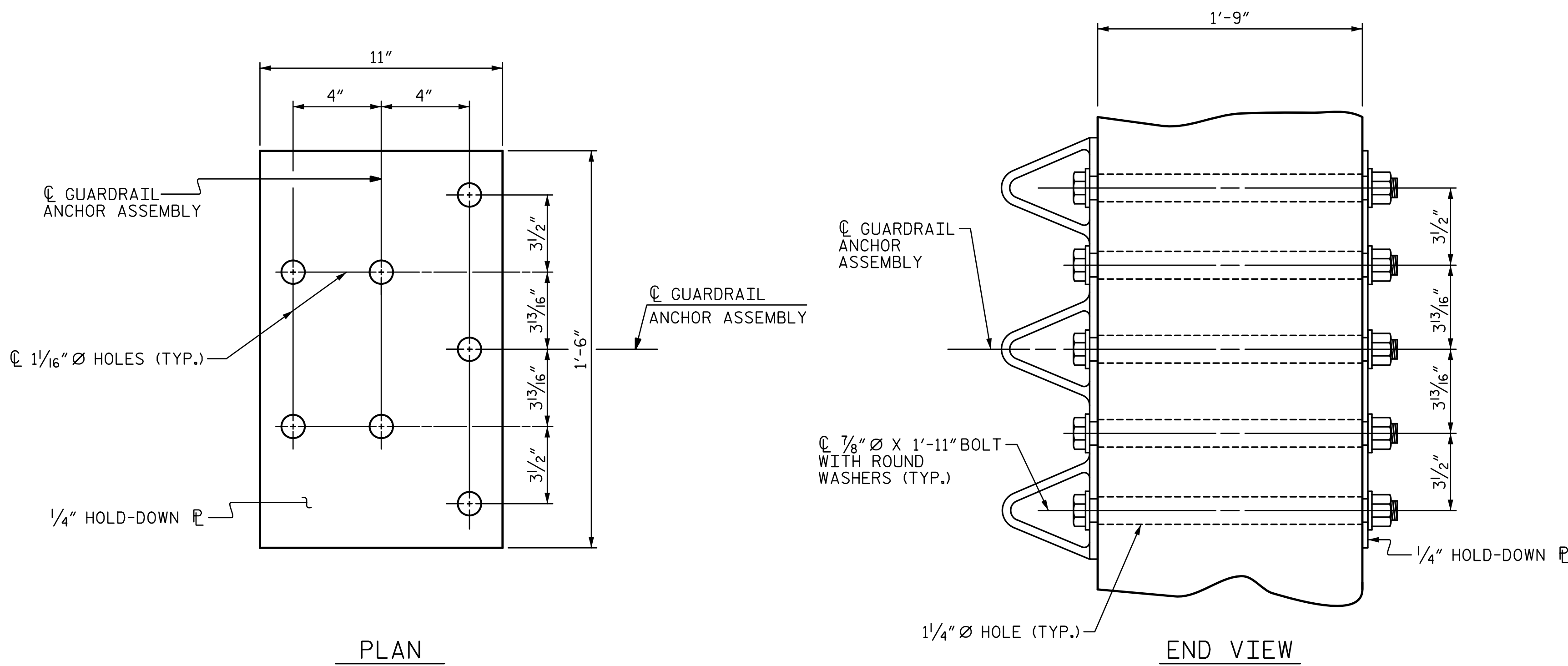

GUARDRAIL ANCHOR ASSEMBLY DETAILS

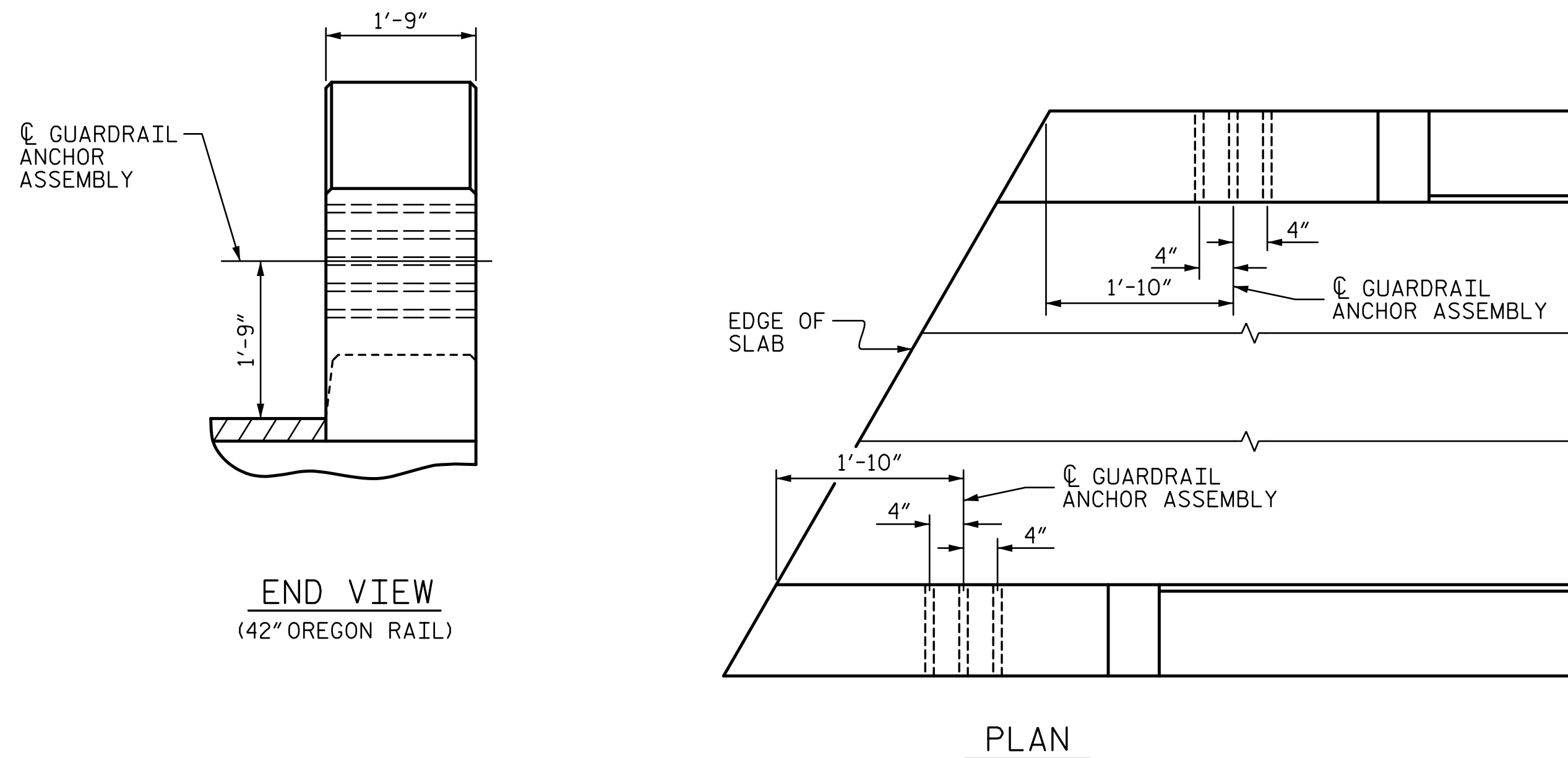

LOCATION OF GUARDRAIL ANCHOR AT END POST

NOTES

THE GUARDRAIL ANCHOR ASSEMBLY SHALL CONSIST OF A 1/4" HOLD DOWN PLATE AND 7 - 7/8" Ø BOLTS WITH NUTS AND WASHERS.

THE HOLD-DOWN PLATE SHALL CONFORM TO AASHTO M270 GRADE 36. AFTER FABRICATION, THE HOLD-DOWN PLATE SHALL BE HOT-DIP GALVANIZED IN ACCORDANCE WITH AASHTO M111.

BOLTS SHALL CONFORM TO THE REQUIREMENTS OF ASTM A307 AND NUTS SHALL CONFORM TO THE REQUIREMENTS OF AASHTO M291. BOLTS, NUTS AND WASHERS SHALL BE GALVANIZED. AT THE CONTRACTOR'S OPTION, STAINLESS STEEL BOLTS, NUTS AND WASHERS MAY BE USED AS AN ALTERNATE FOR THE 7/8" Ø GALVANIZED BOLTS, NUTS AND WASHERS. THEY SHALL CONFORM TO OR EXCEED THE MECHANICAL REQUIREMENTS OF ASTM A307. THE USE OF THIS ALTERNATE SHALL BE APPROVED BY THE ENGINEER.

THE GUARDRAIL ANCHOR ASSEMBLY IS REQUIRED AT ALL POINTS WHERE APPROACH GUARDRAIL IS TO BE ATTACHED TO THE END OF THE PARAPET. FOR POINTS OF ATTACHMENT, SEE SKETCH.

AFTER INSTALLATION, THE EXPOSED THREAD OF THE BOLT SHALL BE BURRED WITH A SHARP POINTED TOOL.

THE COST OF THE GUARDRAIL ANCHOR ASSEMBLIES WITH BOLTS, NUTS AND WASHERS COMPLETE IN PLACE, SHALL BE INCLUDED IN THE VARIOUS PAY ITEMS.

THE VERTICAL REINFORCING BARS MAY BE SHIFTED SLIGHTLY IN THE END POST TO CLEAR ASSEMBLY BOLTS.

THE 1 1/4" Ø HOLES SHALL BE FORMED OR DRILLED WITH A CORE BIT. IMPACT TOOLS WILL NOT BE PERMITTED. ANY CONCRETE DAMAGED BY THIS WORK SHALL BE REPAIRED TO THE SATISFACTION OF THE ENGINEER.

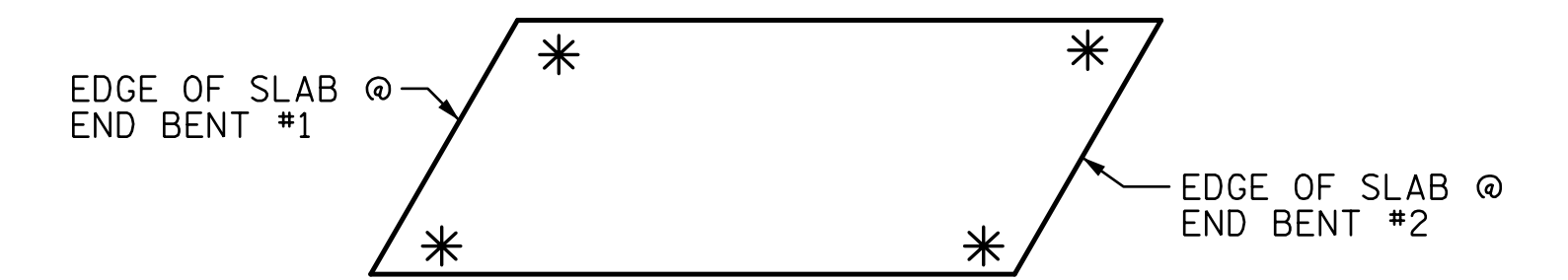

SKETCH SHOWING POINTS OF ATTACHMENT

* LOCATION OF GUARDRAIL ATTACHMENT

PROJECT NO. 17BP.10.R.133
STANLY COUNTY
 STATION: 15+41.00 -L-

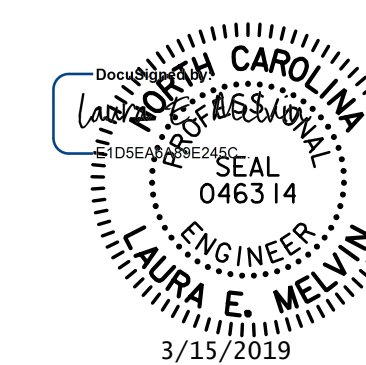

STV 100 YEARS
 STV ENGINEERS, INC.
 900 West Trade St., Suite 715
 Charlotte, NC 28202
 NC License Number F-0991

DOCUMENT NOT CONSIDERED
 FINAL UNLESS ALL
 SIGNATURES COMPLETED

STATE OF NORTH CAROLINA DEPARTMENT OF TRANSPORTATION RALEIGH					
STANDARD GUARDRAIL ANCHORAGE DETAILS FOR METAL RAILS					
REVISIONS					SHEET NO.
NO.	BY:	DATE:	NO.	BY:	DATE:
1			3		
2			4		
					S-10
					TOTAL SHEETS 16

ASSEMBLED BY : CL	DATE : 10-18
CHECKED BY : LEM	DATE : 11-18
DESIGN ENGINEER OF RECORD : LEM	DATE : 12-18
DRAWN BY : MAA 5/10	REV. 1/15 MAA/TMG
CHECKED BY : GM 5/10	REV. 12/17 MAA/THC
	REV. 5/18 MAA/THC

R:\Structures\ustation\Finals\40L_019_17BP_10.R.133_SMU_GR_010_83062.dgn
 3/14/2019 10:17:20 AM MelvinLE

NOTES

STIRRUPS IN CAP MAY BE SHIFTED AS NECESSARY TO CLEAR DOWELS.

THE CONCRETE IN THE SHADED AREA OF THE WING SHALL BE POURED AFTER THE CONCRETE CURB IS CAST IF SLIP FORMING IS USED.

FOR PILE SPLICE DETAILS, SEE SHEET 4 OF 4.

FOR WING DETAILS, SEE SHEET 3 OF 4.

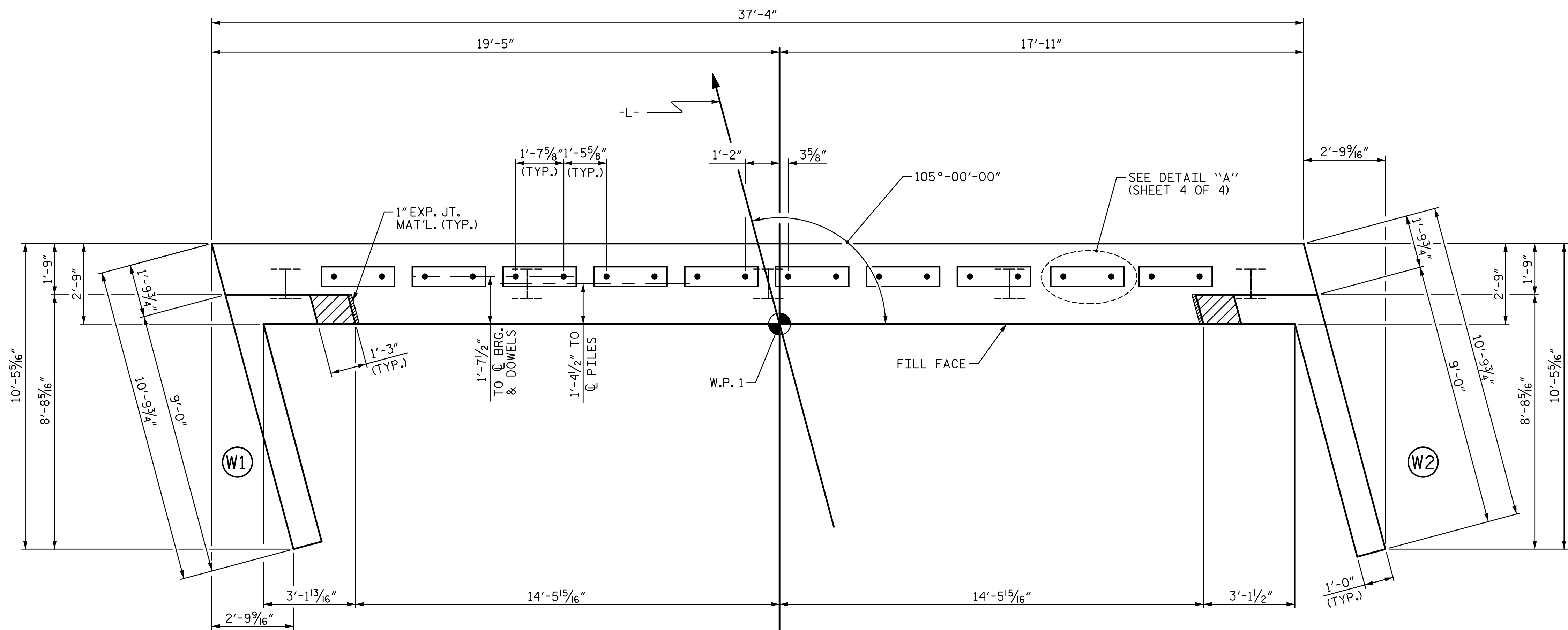

PLAN

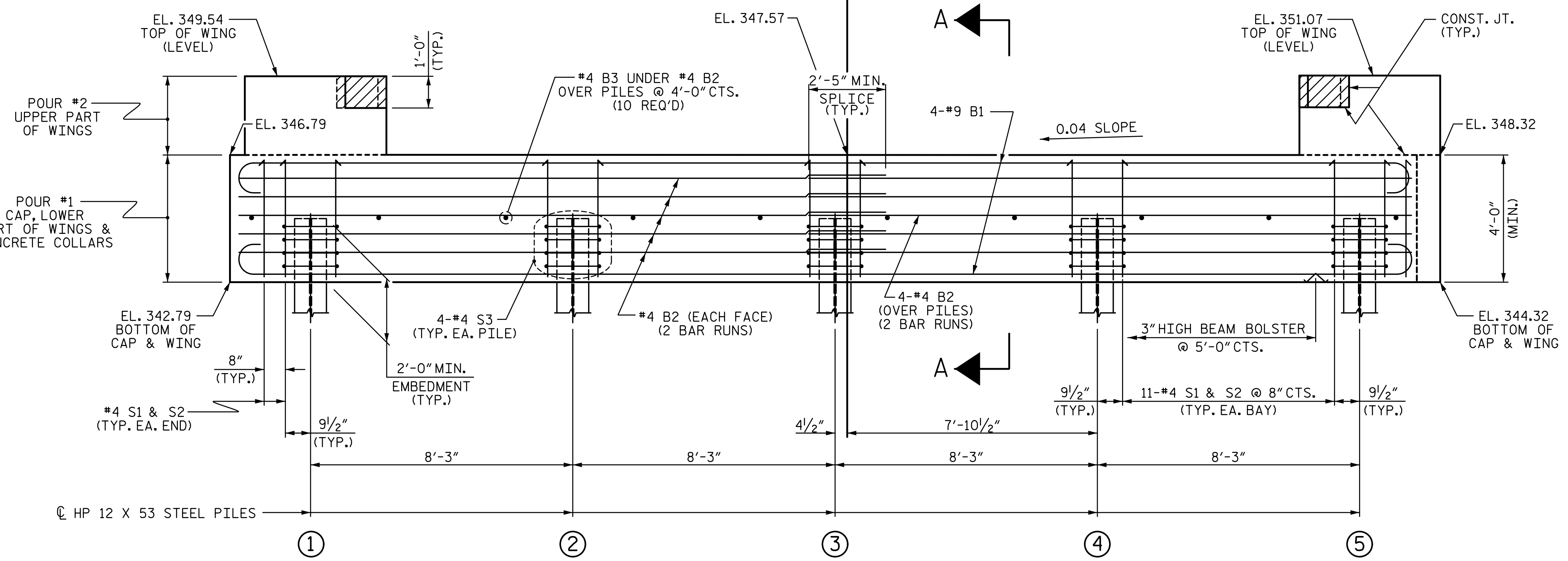

ELEVATION

TOP OF PILE ELEVATIONS	
①	344.92
②	345.25
③	345.58
④	345.91
⑤	346.24

PROJECT NO. 17BP.10.R.133
 STANLY COUNTY
 STATION: 15+41.00 -L-
 SHEET 1 OF 4

STATE OF NORTH CAROLINA
 DEPARTMENT OF TRANSPORTATION
 RALEIGH

SUBSTRUCTURE
 END BENT No. 1

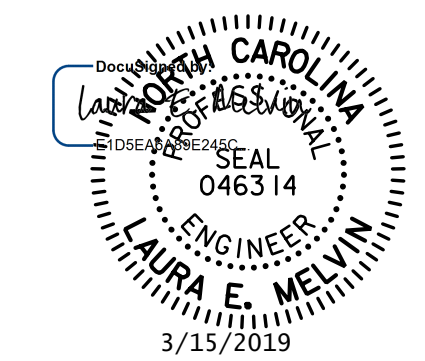

STV 100 YEARS
 STV ENGINEERS, INC.
 900 West Trade St., Suite 715
 Charlotte, NC 28202
 NC License Number F-0991

DOCUMENT NOT CONSIDERED
 FINAL UNLESS ALL
 SIGNATURES COMPLETED

WINGS NOT SHOWN FOR CLARITY.
 FOR SECTION A-A, SEE SHEET 4 OF 4.
 CONCRETE COLLARS FOR STEEL PILES NOT SHOWN IN PLAN AND ELEVATION VIEWS FOR CLARITY.
 SEE "CORROSION PROTECTION FOR STEEL PILES DETAIL", SHEET 4 OF 4.

3/14/2019 10:17:22 AM R:\Structures\ustation\Finals\40L17BP.10.R.133_SMU_EL_OIL.830162.dgn

ASSEMBLED BY : CL	DATE : 10-18
CHECKED BY : LEM	DATE : 11-18
DESIGN ENGINEER OF RECORD : LEM	DATE : 12-18
DRAWN BY : WJH 12/11	REV. 4/15 MAA/TMG
CHECKED BY : AAC 12/11	

REVISIONS					SHEET NO.
NO.	BY:	DATE:	NO.	BY:	DATE:
1			3		
2			4		

TOTAL SHEETS 16

NOTES

STIRRUPS IN CAP MAY BE SHIFTED AS NECESSARY TO CLEAR DOWELS.
 THE CONCRETE IN THE SHADED AREA OF THE WING SHALL BE POURED AFTER THE CONCRETE CURB IS CAST IF SLIP FORMING IS USED.
 FOR PILE SPLICE DETAILS, SEE SHEET 4 OF 4.
 FOR WING DETAILS, SEE SHEET 3 OF 4.

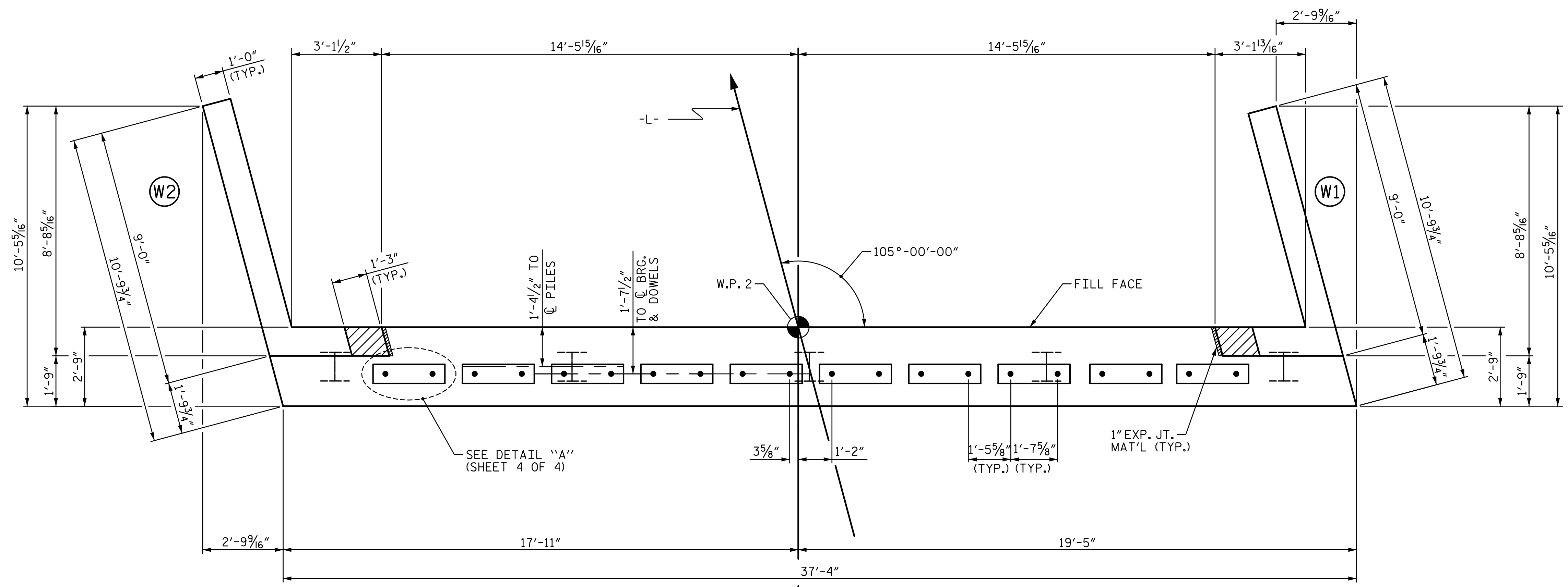

PLAN

TOP OF PILE ELEVATIONS	
①	344.05
②	344.38
③	344.71
④	345.04
⑤	345.37

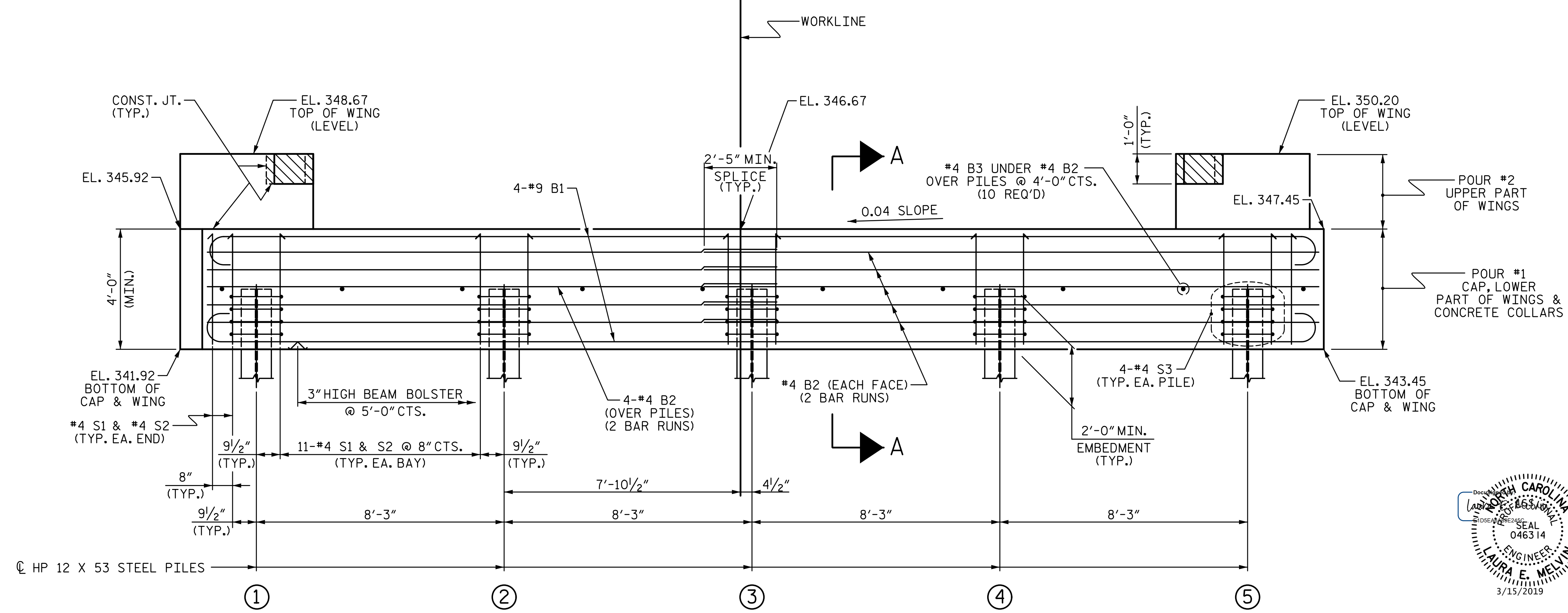

ELEVATION

PROJECT NO. 17BP.10.R.133
 STANLY COUNTY
 STATION: 15+41.00 -L-
 SHEET 2 OF 4

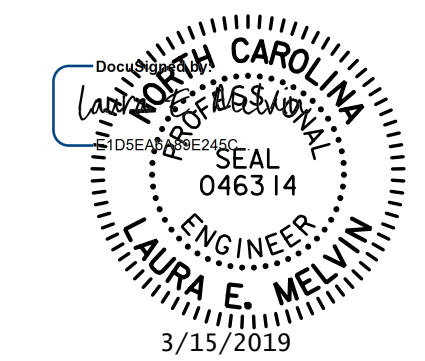

STATE OF NORTH CAROLINA
 DEPARTMENT OF TRANSPORTATION
 RALEIGH
 SUBSTRUCTURE
 END BENT No. 2

STV 100 STV ENGINEERS, INC.
 900 West Trade St., Suite 715
 Charlotte, NC 28202
 NC License Number F-0991

DOCUMENT NOT CONSIDERED FINAL UNLESS ALL SIGNATURES COMPLETED

REVISIONS						SHEET NO.
NO.	BY:	DATE:	NO.	BY:	DATE:	S-12
1			3			TOTAL SHEETS 16
2			4			

WINGS NOT SHOWN FOR CLARITY. FOR SECTION A-A, SEE SHEET 4 OF 4.
 CONCRETE COLLARS FOR STEEL PILES NOT SHOWN IN PLAN AND ELEVATION VIEWS FOR CLARITY. SEE "CORROSION PROTECTION FOR STEEL PILES DETAIL", SHEET 4 OF 4.

3/14/2019 10:17:24 AM R:\Structures\ustation\Finals\40L_023_17BP.10.R.133_SML_E2_012_830162.dgn

ASSEMBLED BY : CL	DATE : 10-18
CHECKED BY : LEM	DATE : 11-18
DESIGN ENGINEER OF RECORD : LEM	DATE : 12-18
DRAWN BY : WJH 12/11	REV. 4/15 MAA/TMG
CHECKED BY : AAC 12/11	

3/14/2019 10:17:26 AM R:\S\Structures\ustation\Finals\40L_025_17BP.10.R.133_SML_E3_013_830162.dgn

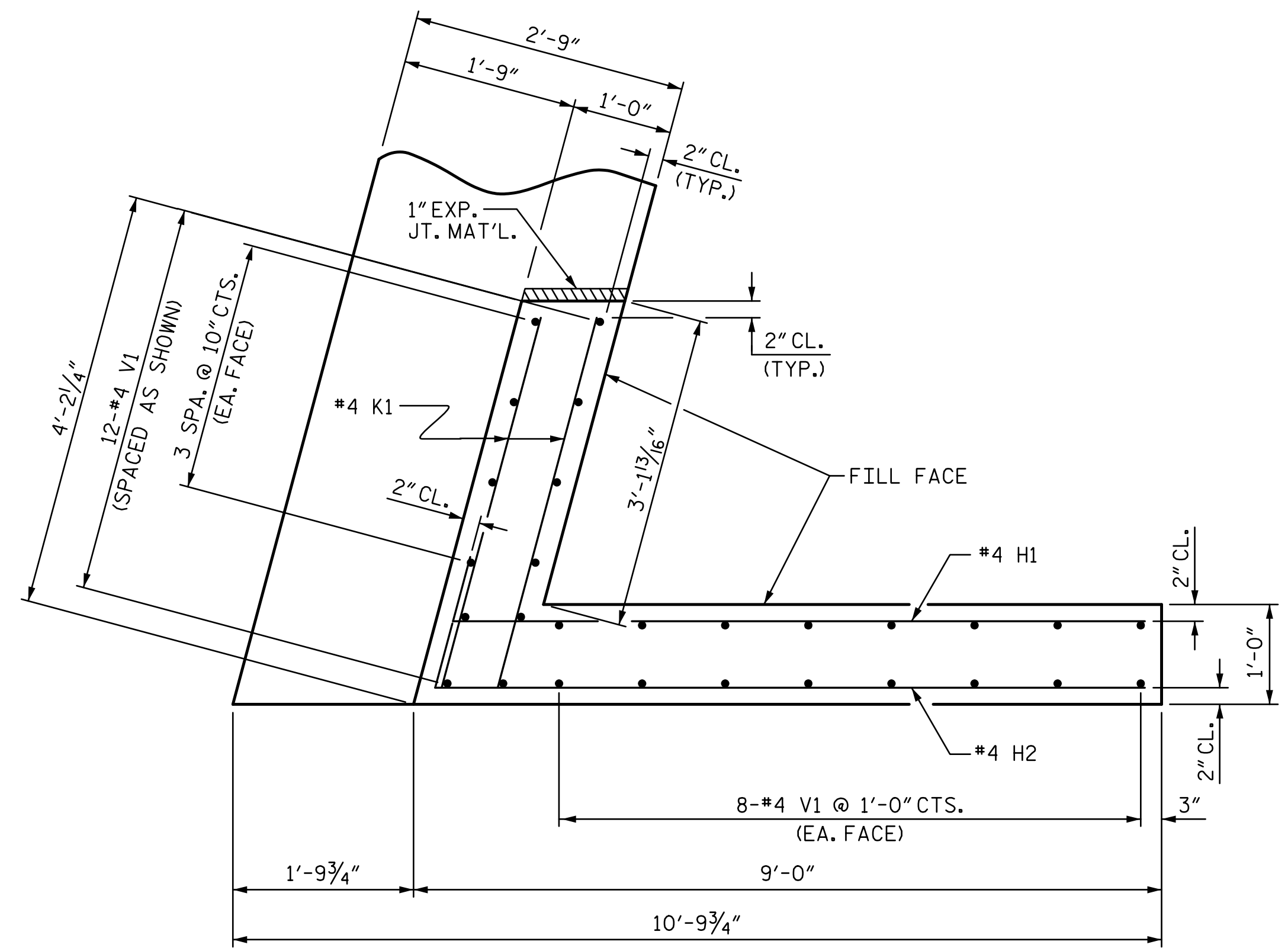

PLAN OF WING (W1)

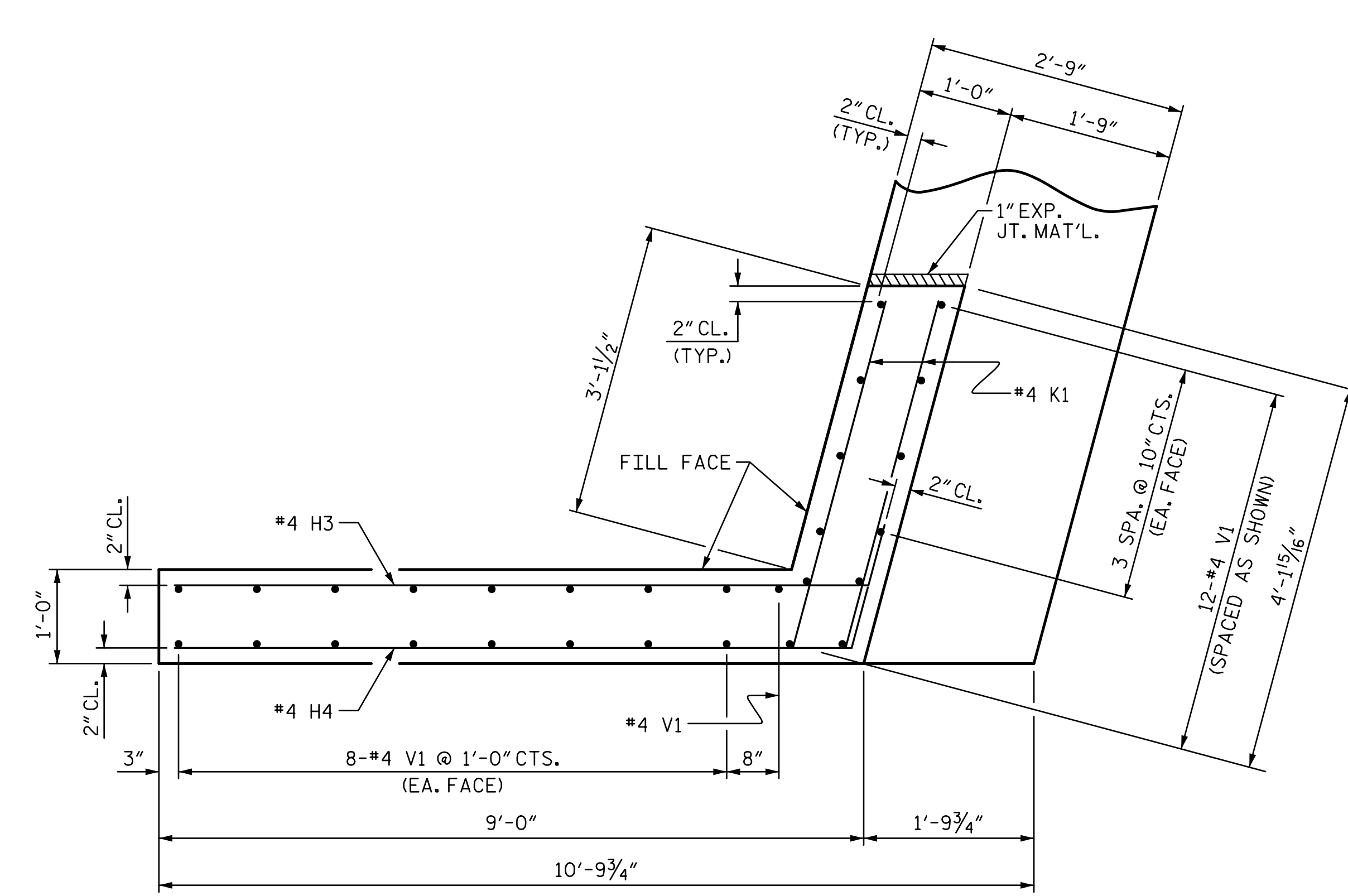

PLAN OF WING (W2)

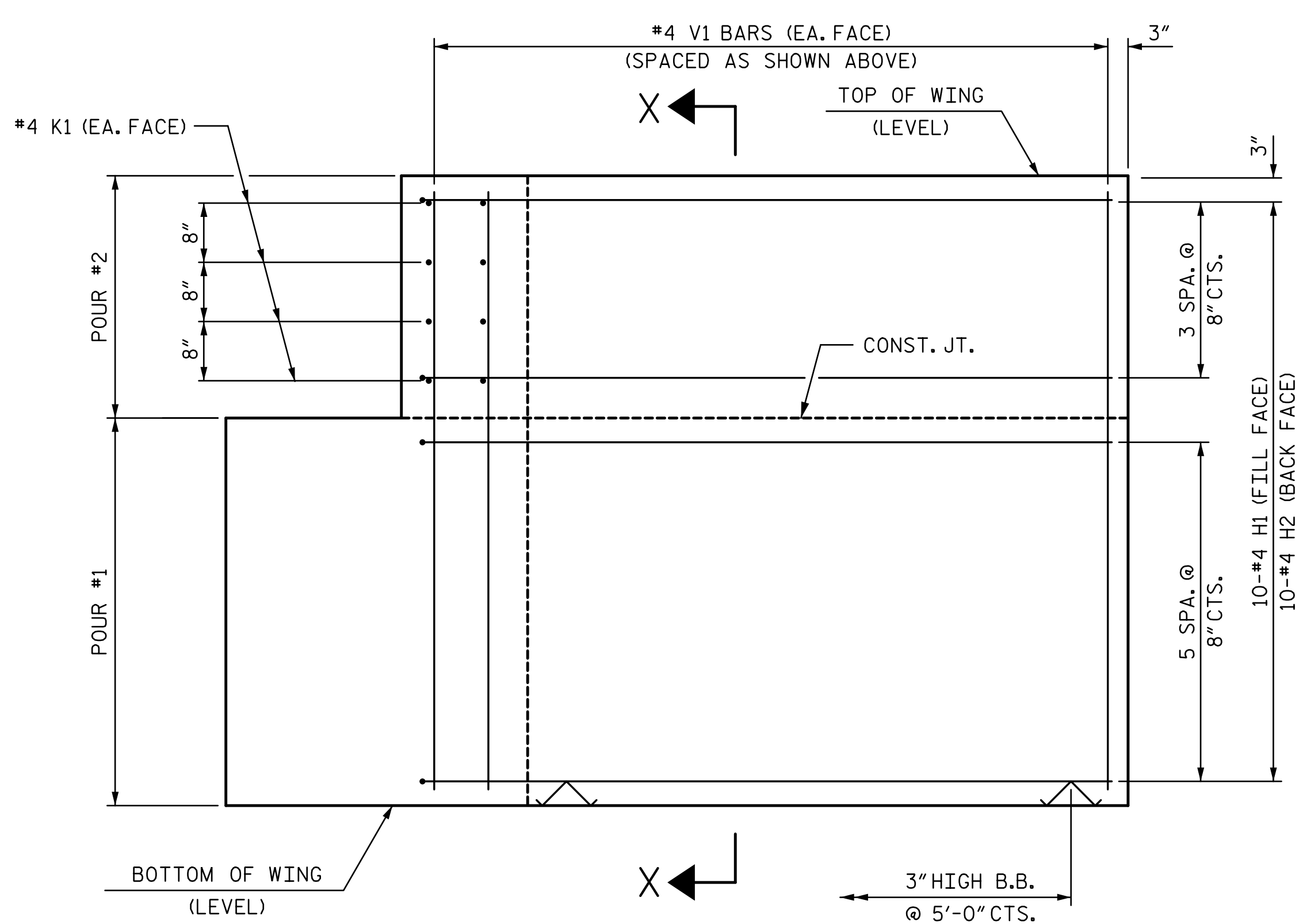

ELEVATION OF WING (W1)

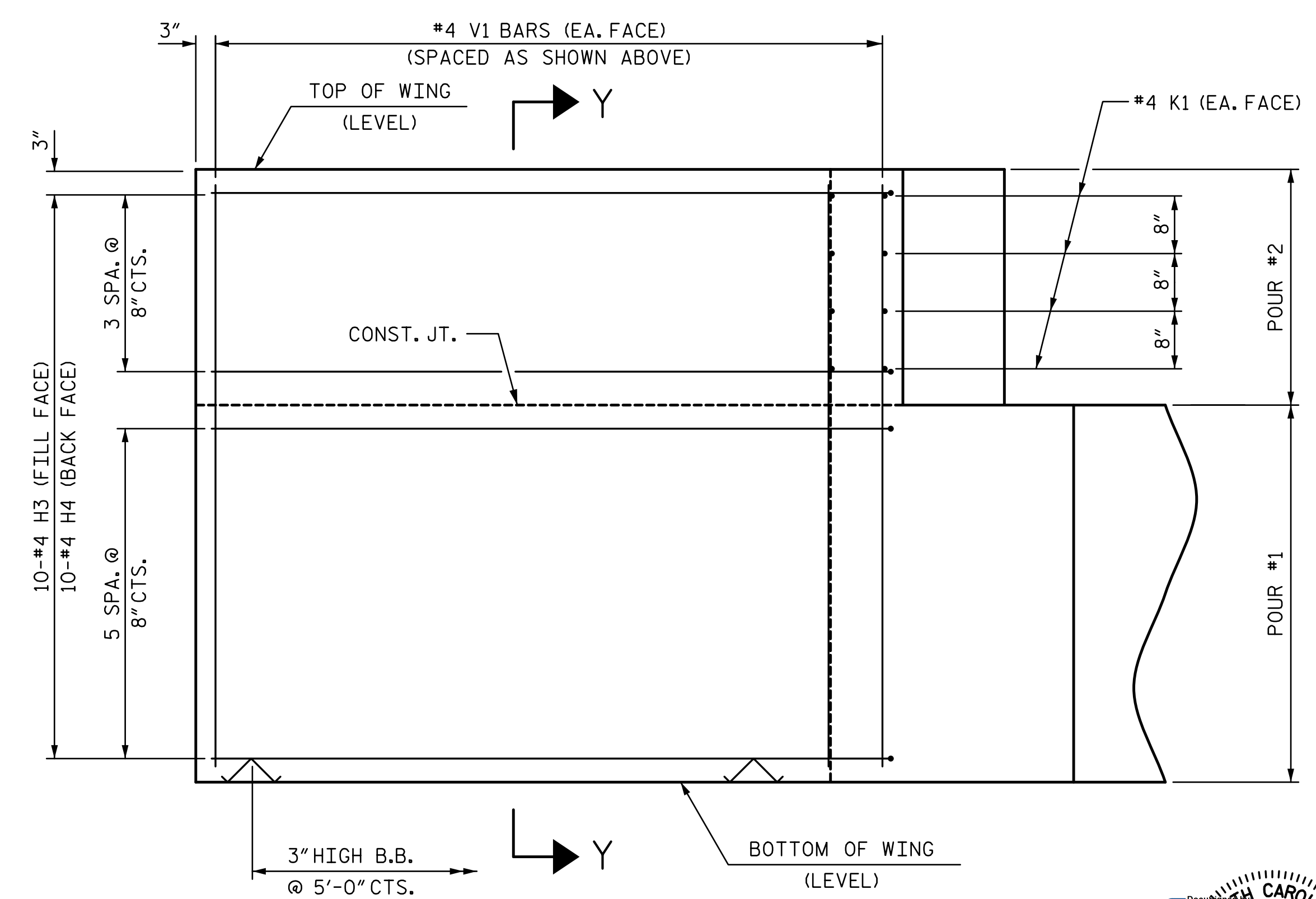

ELEVATION OF WING (W2)

WING DETAILS

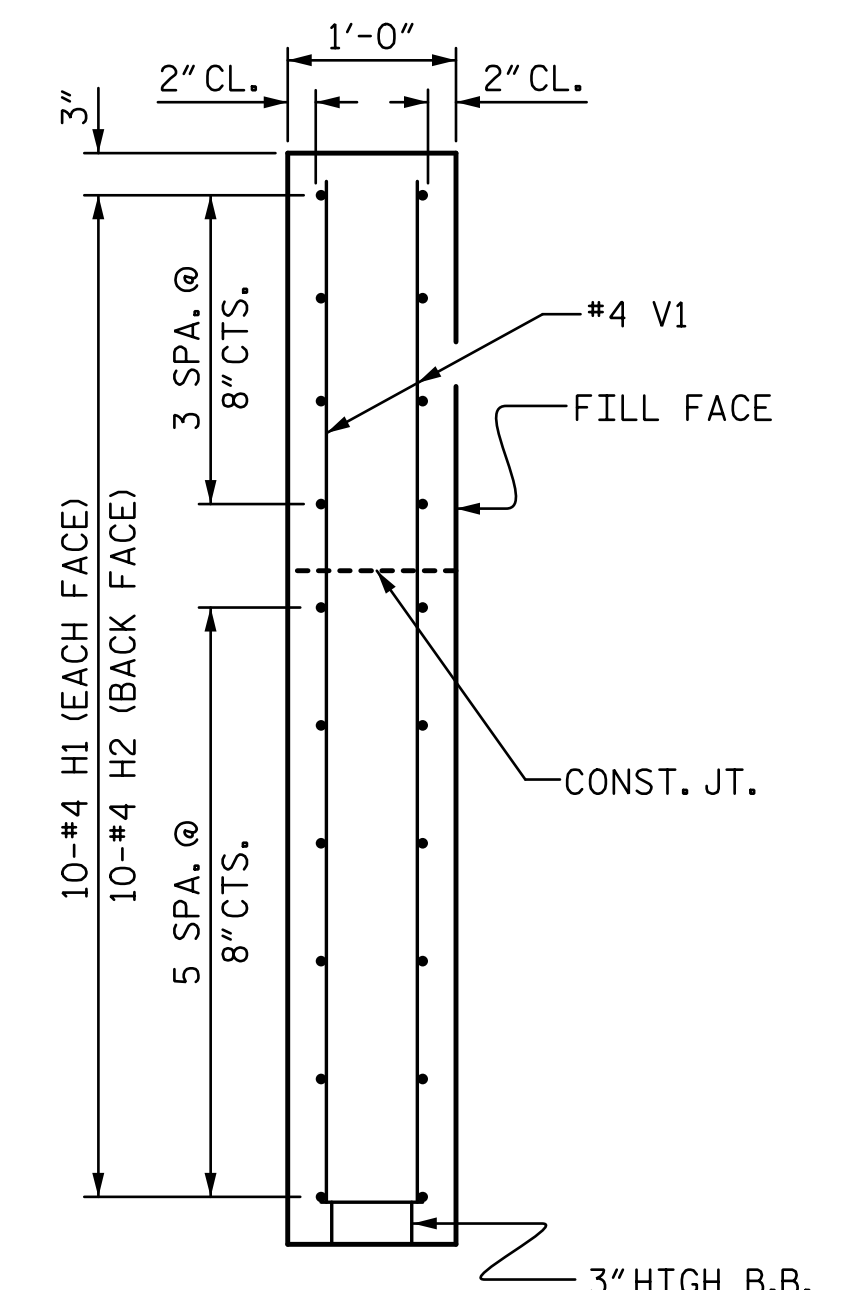

SECTION X-X

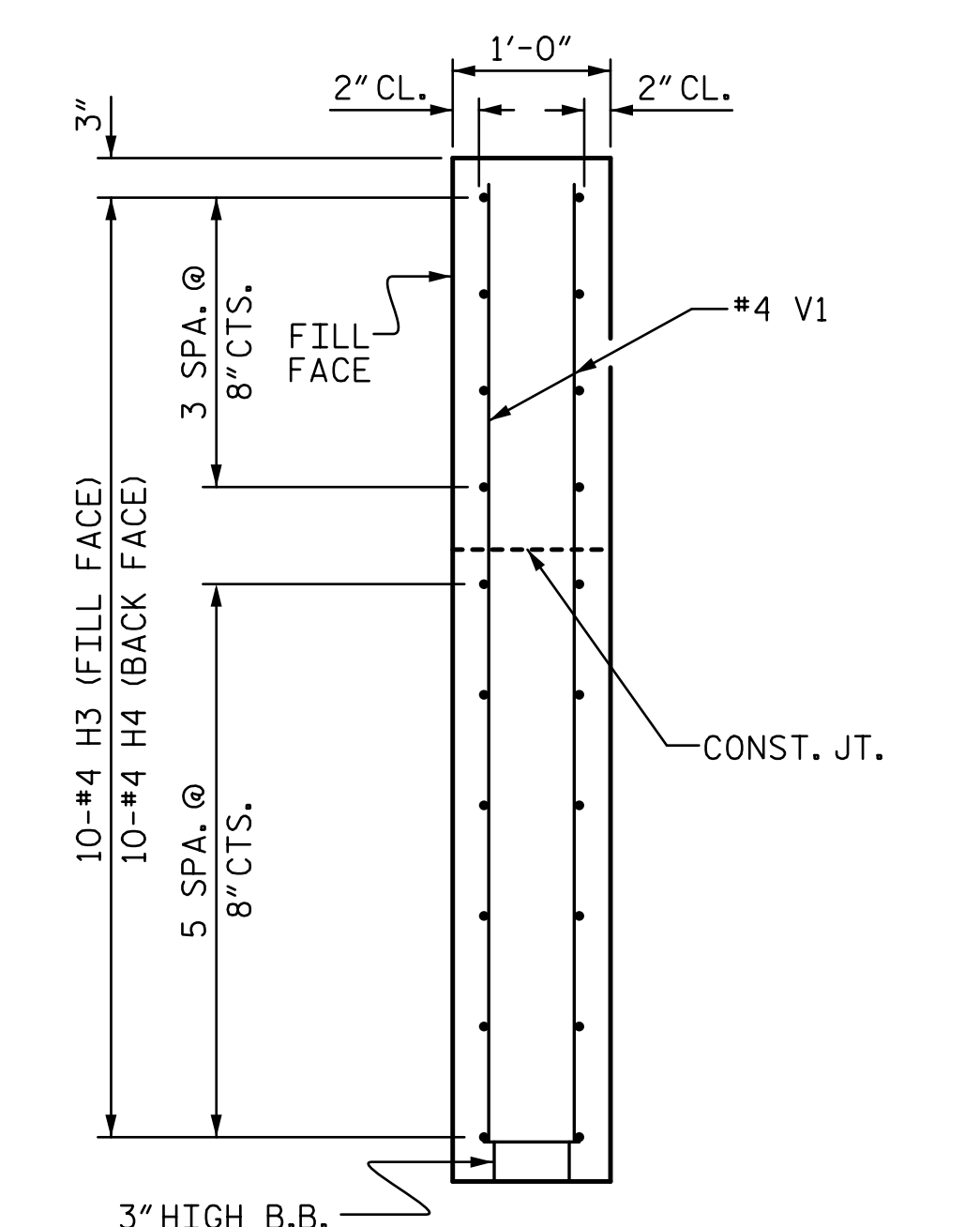

SECTION Y-Y

PROJECT NO. 17BP.10.R.133
 STANLY COUNTY
 STATION: 15+41.00 -L-
 SHEET 3 OF 4

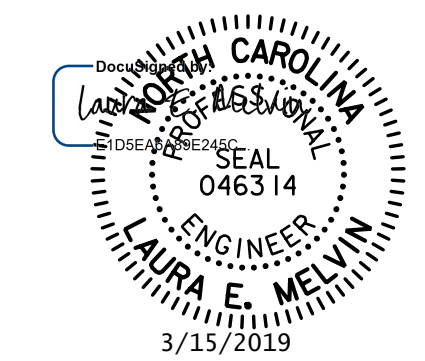

STV 100 YEARS
 STV ENGINEERS, INC.
 900 West Trade St., Suite 715
 Charlotte, NC 28202
 NC License Number F-0991

DOCUMENT NOT CONSIDERED
 FINAL UNLESS ALL
 SIGNATURES COMPLETED

ASSEMBLED BY : CL	DATE : 10-18
CHECKED BY : LEM	DATE : 11-18
DESIGN ENGINEER OF RECORD : LEM	DATE : 12-18
DRAWN BY : WJH 12/11	REV. 4/15 MAA/TMG
CHECKED BY : AAC 12/11	

STATE OF NORTH CAROLINA DEPARTMENT OF TRANSPORTATION RALEIGH					
SUBSTRUCTURE END BENT WING DETAILS					
REVISIONS					SHEET NO.
NO.	BY:	DATE:	NO.	BY:	DATE:
1			3		
2			4		
					S-13
					TOTAL SHEETS 16

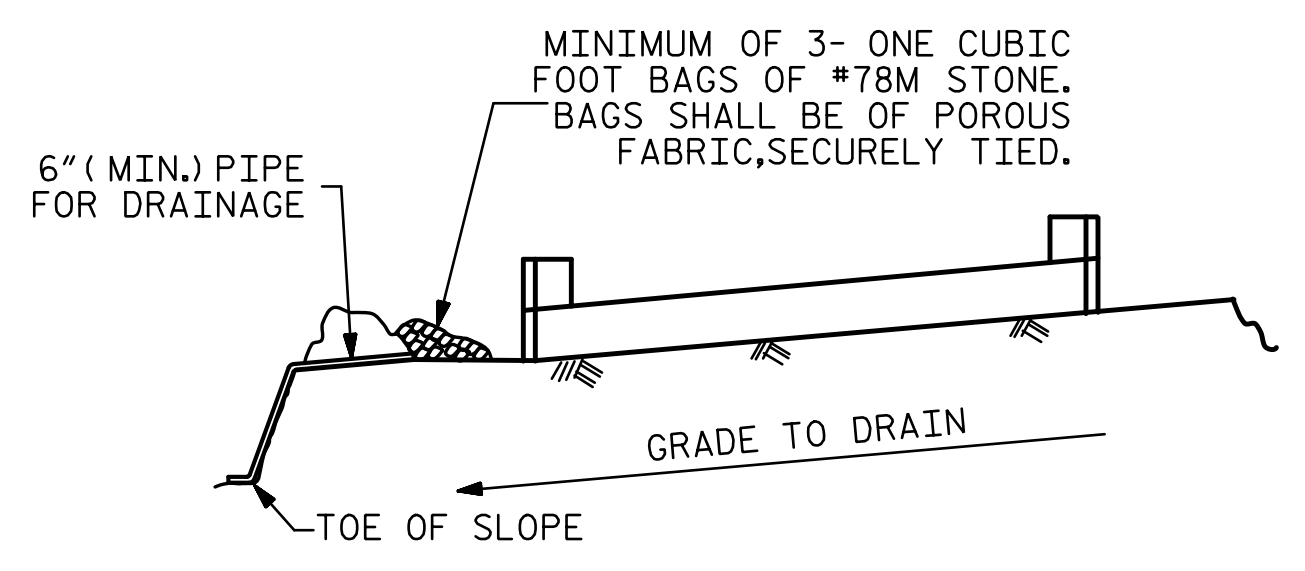

BAGGED STONE AND PIPE SHALL BE PLACED IMMEDIATELY AFTER COMPLETION OF END BENT EXCAVATION. PIPE MAY BE EITHER CONCRETE, CORRUGATED STEEL, CORRUGATED ALUMINUM ALLOY, OR CORRUGATED PLASTIC. PERFORATED PIPE WILL NOT BE ALLOWED.

BAGGED STONE SHALL REMAIN IN PLACE UNTIL THE ENGINEER DIRECTS THAT IT BE REMOVED. THE CONTRACTOR SHALL REMOVE AND DISPOSE OF SILT ACCUMULATIONS AT BAGGED STONE WHEN SO DIRECTED BY THE ENGINEER. BAGS SHALL BE REMOVED AND REPLACED WHENEVER THE ENGINEER DETERMINES THAT THEY HAVE DETERIORATED AND LOST THEIR EFFECTIVENESS.

NO SEPARATE PAYMENT WILL BE MADE FOR THIS WORK AND THE ENTIRE COST OF THIS WORK SHALL BE INCLUDED IN THE UNIT CONTRACT PRICE BID FOR THE SEVERAL PAY ITEMS.

TEMPORARY DRAINAGE AT END BENT

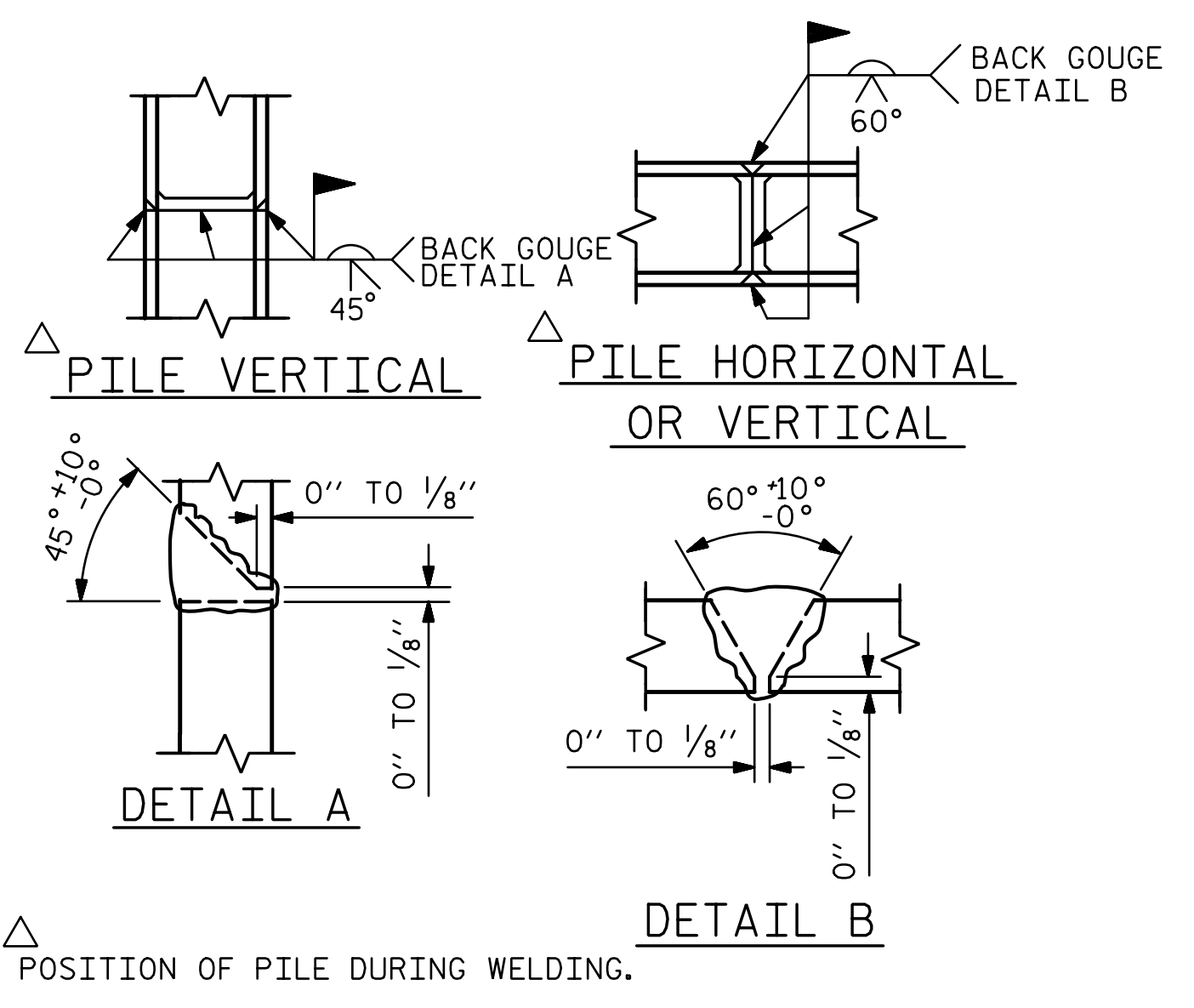

PILE SPLICE DETAILS

BAR TYPES	
①	②
③	④
⑤	⑥

ALL BAR DIMENSIONS ARE OUT TO OUT.

END BENT No. 1	END BENT No. 2
HP 12 X 53 STEEL PILES NO: 5 LIN. FT.= 39	HP 12 X 53 STEEL PILES NO: 5 LIN. FT.= 62
PILE DRIVING EQUIPMENT SETUP FOR HP 12 X 53 STEEL PILES NO: 5	PILE DRIVING EQUIPMENT SETUP FOR HP 12 X 53 STEEL PILES NO: 5

BILL OF MATERIAL FOR ONE END BENT					
BAR NO.	NO.	SIZE	TYPE	LENGTH	WEIGHT
B1	8	#9	1	39'-4"	1070
B2	28	#4	STR	19'-9"	369
B3	10	#4	STR	2'-5"	16
D1	20	#6	STR	1'-6"	45
H1	10	#4	2	9'-1"	61
H2	10	#4	2	9'-3"	62
H3	10	#4	3	9'-6"	63
H4	10	#4	3	9'-4"	62
K1	16	#4	STR	3'-9"	40
S1	48	#4	4	10'-5"	334
S2	48	#4	5	3'-2"	102
S3	20	#4	6	6'-6"	87
V1	57	#4	STR	6'-2"	235
REINFORCING STEEL (FOR ONE END BENT)					2546 LBS.
CLASS A CONCRETE BREAKDOWN (FOR ONE END BENT)					
POUR #1 CAP, LOWER PART OF WINGS & COLLARS				18.4 C.Y.	
POUR #2 UPPER PART OF WINGS				2.5 C.Y.	
TOTAL CLASS A CONCRETE				20.9 C.Y.	

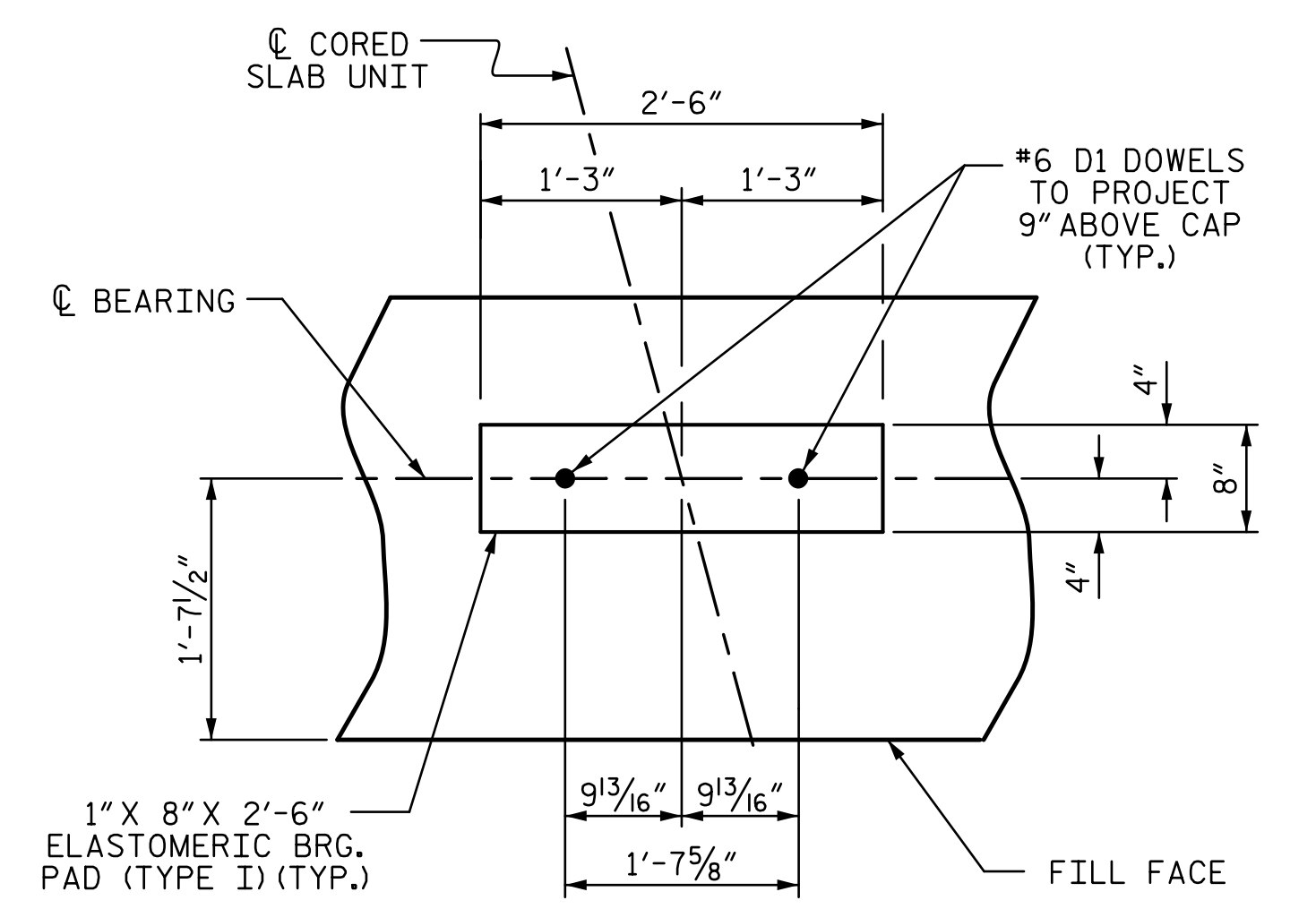

DETAIL "A"

(END BENT No. 1 SHOWN, END BENT No. 2 SIMILAR BY ROTATION)

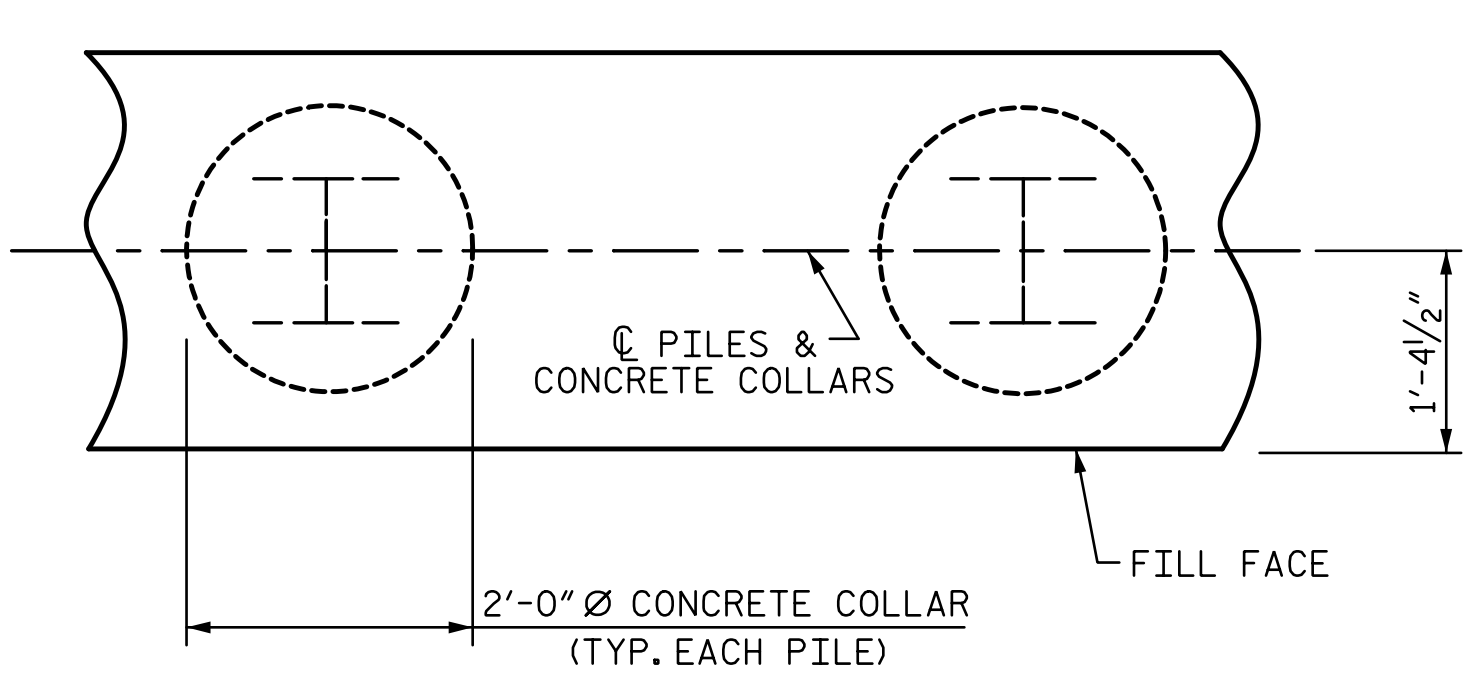

PLAN

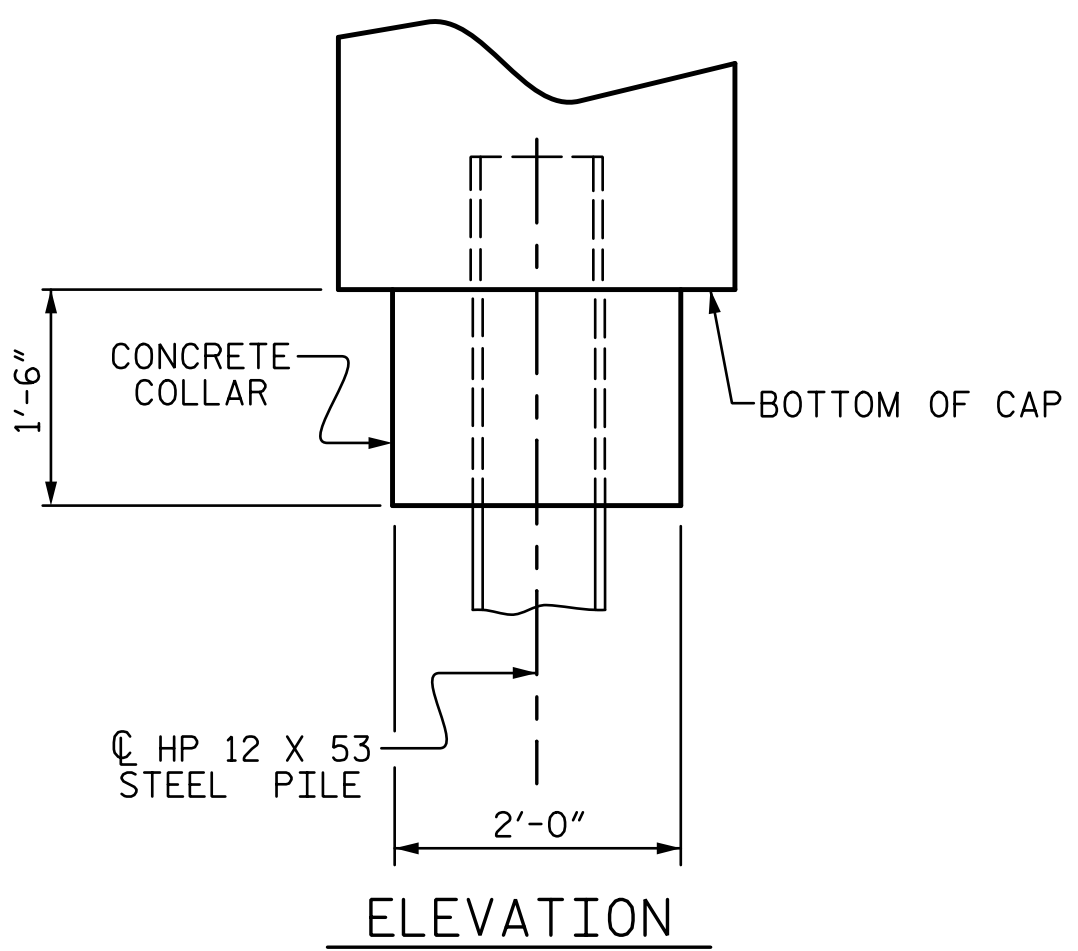

ELEVATION

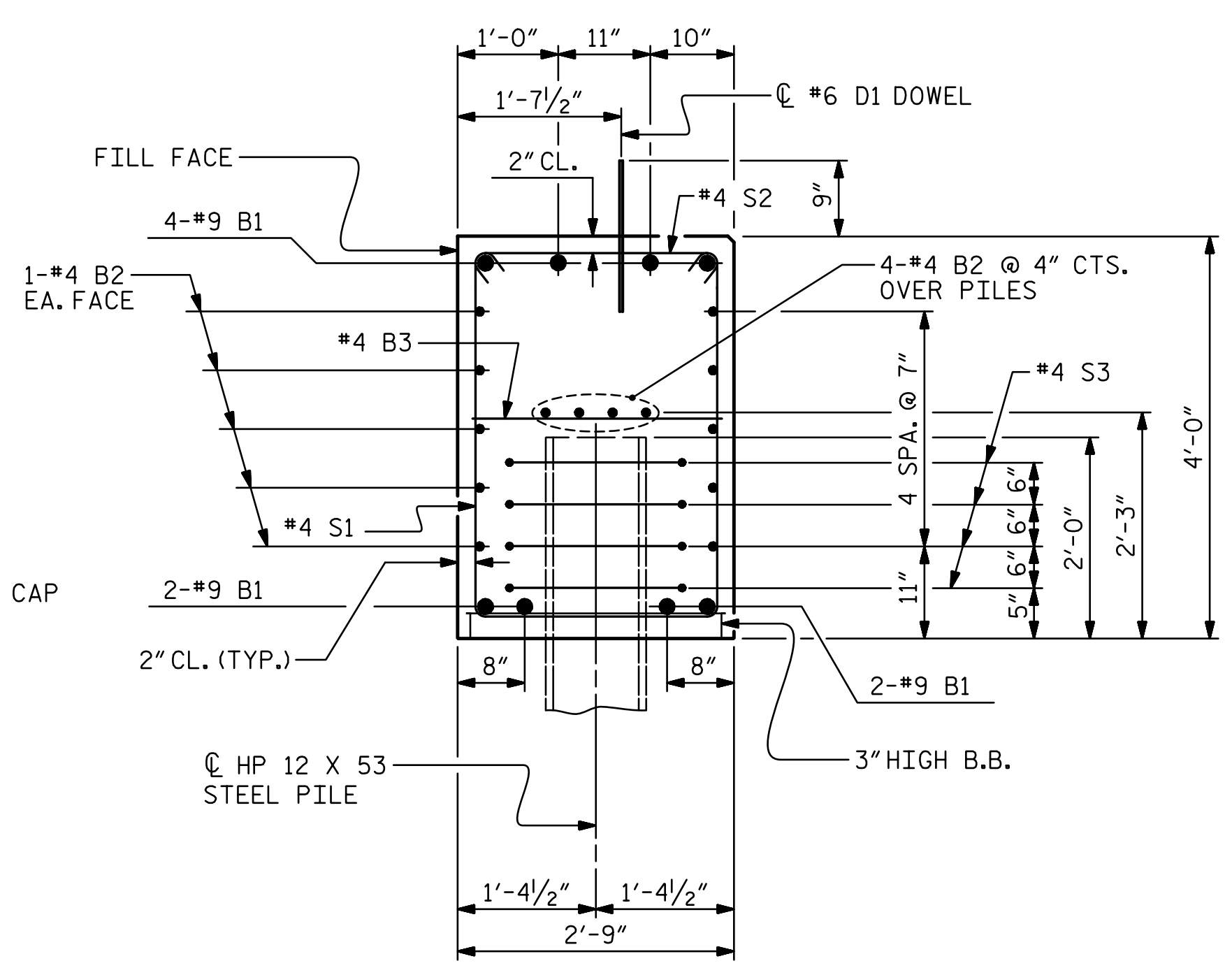

SECTION A-A

(CONCRETE COLLAR NOT SHOWN FOR CLARITY. SEE "CORROSION PROTECTION FOR STEEL PILES DETAIL.")

CORROSION PROTECTION FOR STEEL PILES DETAIL

(END BENT No. 1 SHOWN, END BENT No. 2 SIMILAR BY ROTATION)

PROJECT NO. 17BP.10.R.133
STANLY COUNTY
STATION: 15+41.00 -L-
SHEET 4 OF 4

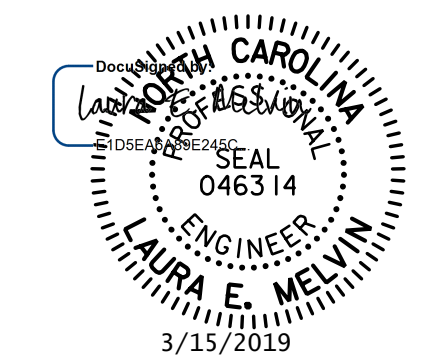

STV ENGINEERS, INC.
900 West Trade St., Suite 715
Charlotte, NC 28202
NC License Number F-0991

DOCUMENT NOT CONSIDERED FINAL UNLESS ALL SIGNATURES COMPLETED

STATE OF NORTH CAROLINA
DEPARTMENT OF TRANSPORTATION
RALEIGH
SUBSTRUCTURE
END BENT No. 1 & 2
DETAILS

REVISIONS				SHEET NO.
NO.	BY:	DATE:	NO.	DATE:
1			3	
2			4	

S-14
TOTAL SHEETS 16

3/14/2019 10:17:28 AM R:\Structures\ustation\Finals\40L027_17BP.10.R.133_SML_E4_04_830162.dgn

ASSEMBLED BY : CL	DATE : 10-18
CHECKED BY : LEM	DATE : 11-18
DESIGN ENGINEER OF RECORD : LEM	DATE : 12-18
DRAWN BY : WJH 12/11	REV. 4/17
CHECKED BY : AAC 12/11	MAA/THC

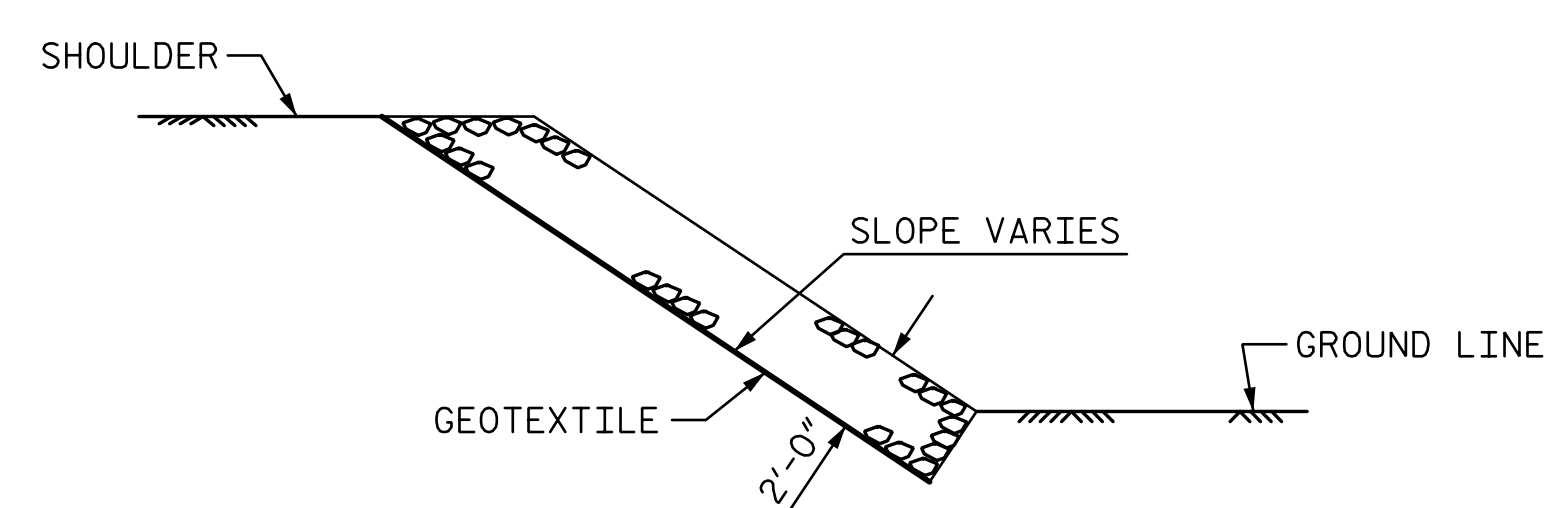
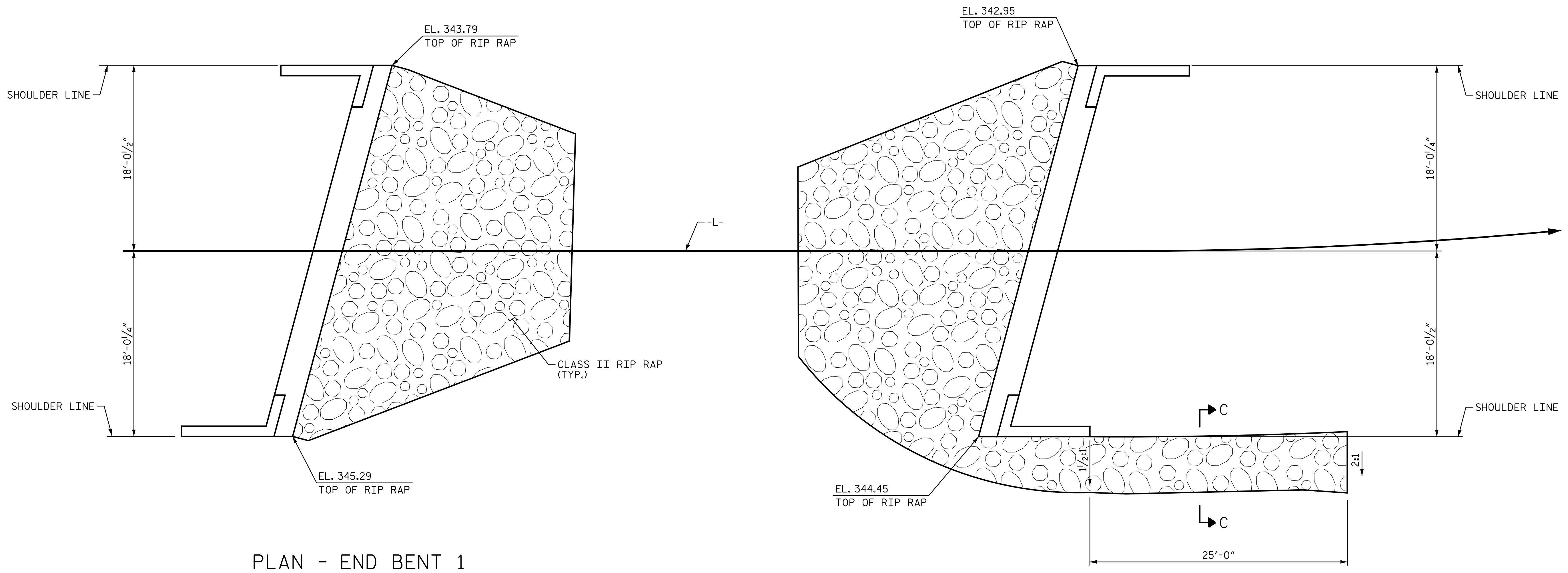

SECTION C-C

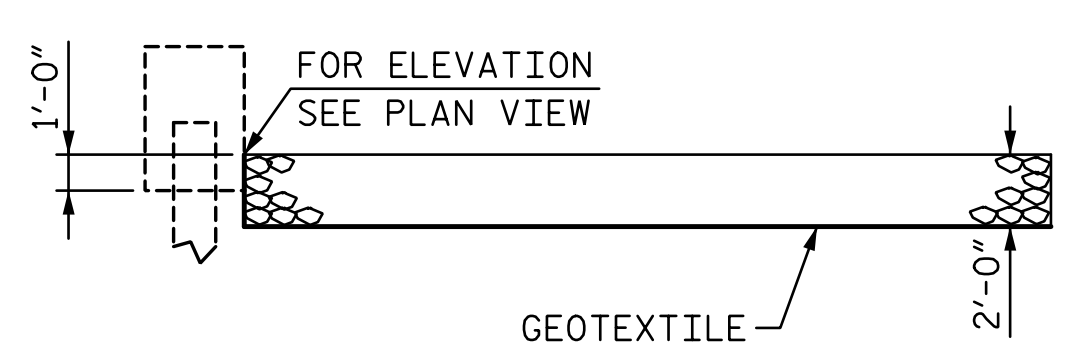

SECTION BERM RIP RAPPED

ESTIMATED QUANTITIES		
BRIDGE @ STA. 15+41.00 -L-	RIP RAP CLASS II (2'-0" THICK)	GEOTEXTILE FOR DRAINAGE
	TONS	SQUARE YARDS
END BENT 1	65	75
END BENT 2	100	110

PROJECT NO. 17BP.10.R.133
STANLY COUNTY
 STATION: 15+41.00 -L-

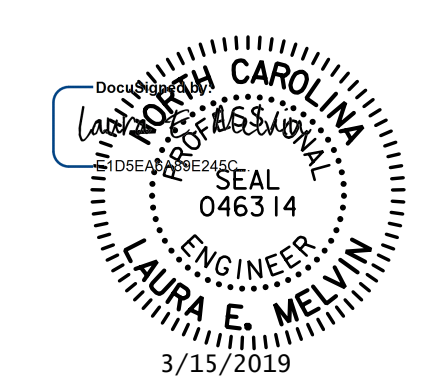

STV 100 Years
 STV ENGINEERS, INC.
 900 West Trade St., Suite 715
 Charlotte, NC 28202
 NC License Number F-0991

DOCUMENT NOT CONSIDERED
 FINAL UNLESS ALL
 SIGNATURES COMPLETED

STATE OF NORTH CAROLINA
 DEPARTMENT OF TRANSPORTATION
 RALEIGH

RIP RAP DETAILS

REVISIONS					SHEET NO.
NO.	BY:	DATE:	NO.	BY:	DATE:
1			3		
2			4		

S-15
 TOTAL SHEETS 16

R:\Structures\ustation\Finals\40L_029_17BP.10.R.133_SML_PP_015_830162.dgn
 3/14/2019 10:17:30 AM
 MeivnLE

DRAWN BY : CL DATE : 10-18
 CHECKED BY : LEM DATE : 11-18
 DESIGN ENGINEER OF RECORD : LEM DATE : 12-18

R:\Structures\ustation\Finals\401_031_17BP.10.R.133_SMU_AS_016_83062.dgn 10/17:31 AM 3/14/2019

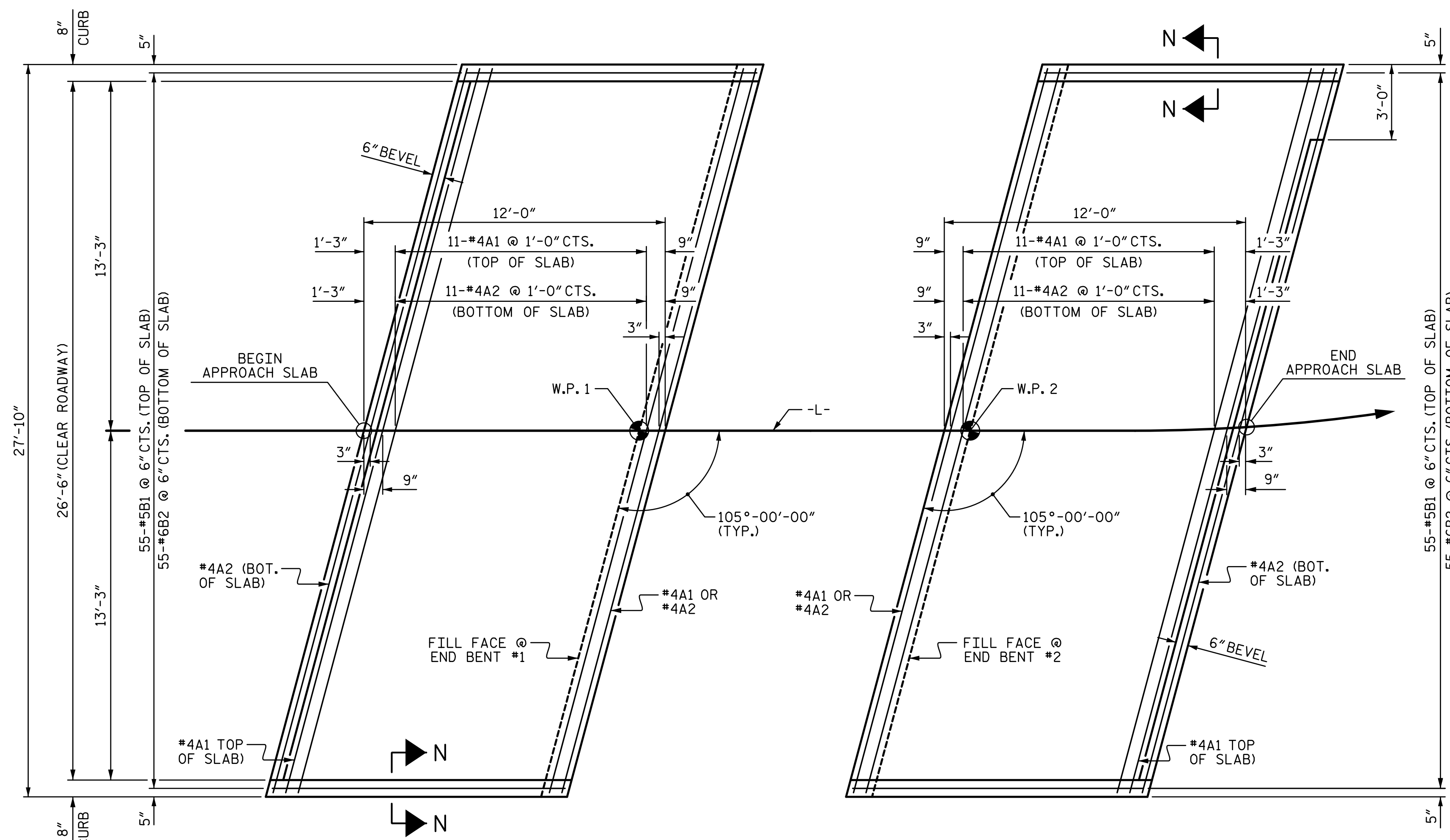

PLAN @ END BENT #1 **PLAN @ END BENT #2**
 DIMENSIONS SHOWN ARE TYPICAL FOR BOTH APPROACH SLABS

NOTES

FOR BRIDGE APPROACH FILL INCLUDING GEOTEXTILE, 4" Ø DRAINAGE PIPE, AND SELECT MATERIAL BACKFILL, SEE ROADWAY PLANS.

GEOTEXTILE SHALL BE TYPE 1 IN ACCORDANCE WITH THE STANDARD SPECIFICATIONS SECTION 1056.

SELECT MATERIAL BACKFILL (CLASS V OR CLASS VI) SHALL BE IN ACCORDANCE WITH STANDARD SPECIFICATIONS SECTION 1016.

SELECT MATERIAL BACKFILL IS TO BE CONTINUOUS ALONG FILL FACE OF BACKWALL FROM OUTSIDE EDGE OF APPROACH SLAB.

FOR THE 4" Ø DRAINAGE PIPE OUTLET(S), SEE ROADWAY STANDARD DRAWINGS.

AREA BETWEEN THE WINGWALL AND APPROACH SLAB SHALL BE GRADED TO DRAIN THE WATER AWAY FROM THE FILL FACE OF THE BRIDGE AND SHALL BE PAVED. SEE ROADWAY PLANS.

APPROACH SLAB GROOVING IS NOT REQUIRED.

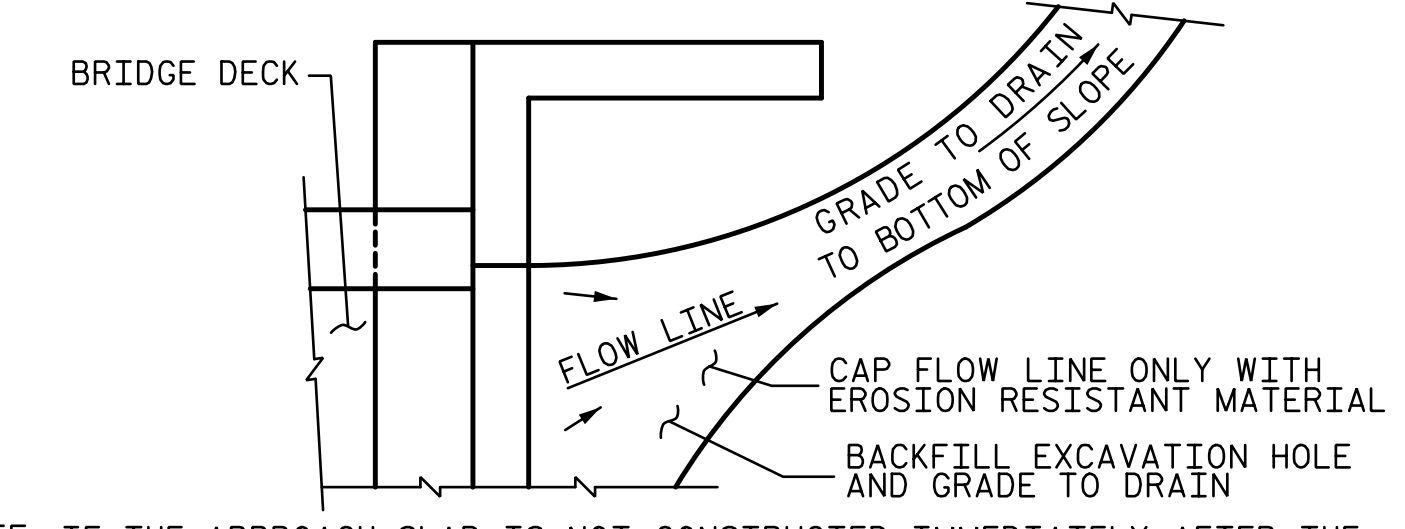

NOTE: IF THE APPROACH SLAB IS NOT CONSTRUCTED IMMEDIATELY AFTER THE BACKFILLING OF THE END BENT EXCAVATION, GRADE TO DRAIN TO THE BOTTOM OF THE SLOPE AND PROVIDE EROSION RESISTANT MATERIAL, SUCH AS FIBERGLASS ROVING OR AS DIRECTED BY THE ENGINEER TO PREVENT SOIL EROSION AND TO PROTECT THE AREA ADJACENT TO THE STRUCTURE. THE CONTRACTOR WILL BE REQUIRED TO REMOVE THESE MATERIALS PRIOR TO CONSTRUCTION OF THE APPROACH SLAB.

TEMPORARY DRAINAGE DETAIL

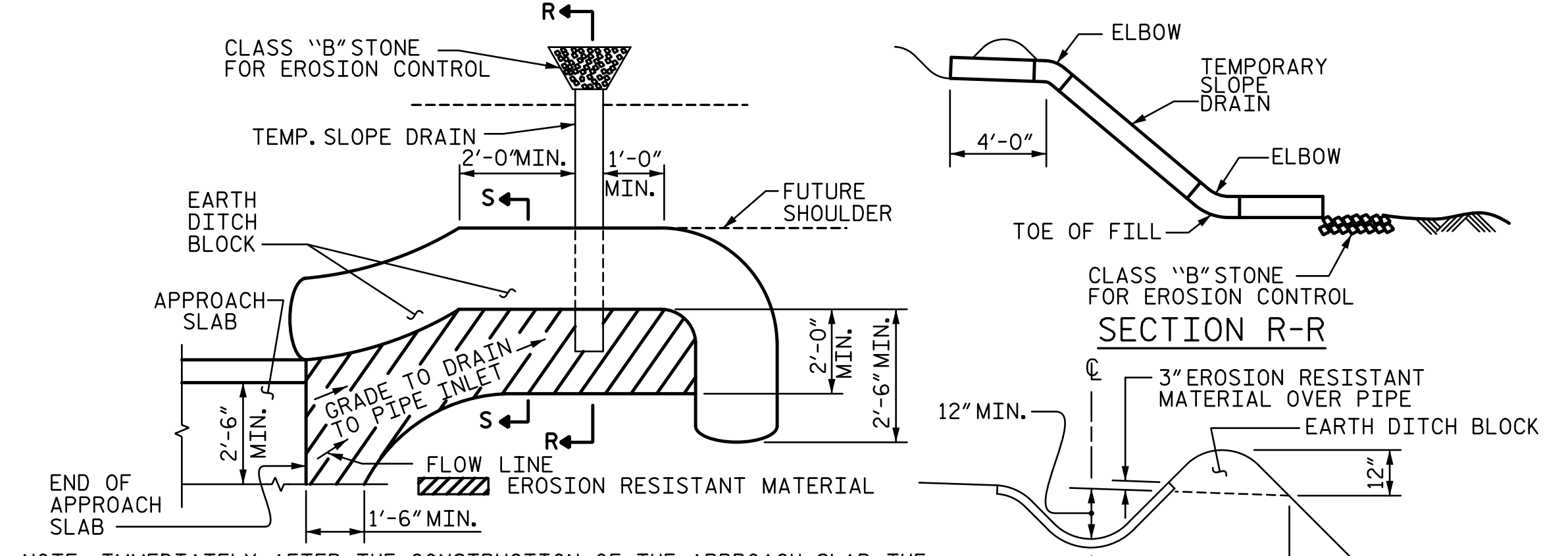

NOTE: IMMEDIATELY AFTER THE CONSTRUCTION OF THE APPROACH SLAB, THE CONTRACTOR SHALL PROVIDE TEMPORARY BERM AND SLOPE DRAIN. CONTRACTOR SHALL GRADE TO PIPE INLET AND PROVIDE EROSION RESISTANT MATERIAL AS SHOWN. THE EROSION RESISTANT MATERIAL SHALL BE EITHER 1) ASPHALT PLANT MIX, TYPE 1 OR TYPE 2, MIN. 2" DEPTH, 2) EROSION CONTROL MAT, OR 3) CONCRETE, AS DIRECTED BY THE ENGINEER. THE SLOPE DRAIN SHALL CONSIST OF A NON-PERFORATED TEMPORARY DRAINAGE PIPE, 12 INCHES IN DIAMETER.

TEMPORARY BERM AND SLOPE DRAIN DETAILS
 (TO BE USED WHEN SHOULDER BERM GUTTER IS REQUIRED)

SPLICE LENGTHS

BAR SIZE	EPOXY COATED	UNCOATED
#4	2'-0"	1'-9"
#5	2'-6"	2'-2"
#6	3'-10"	2'-7"

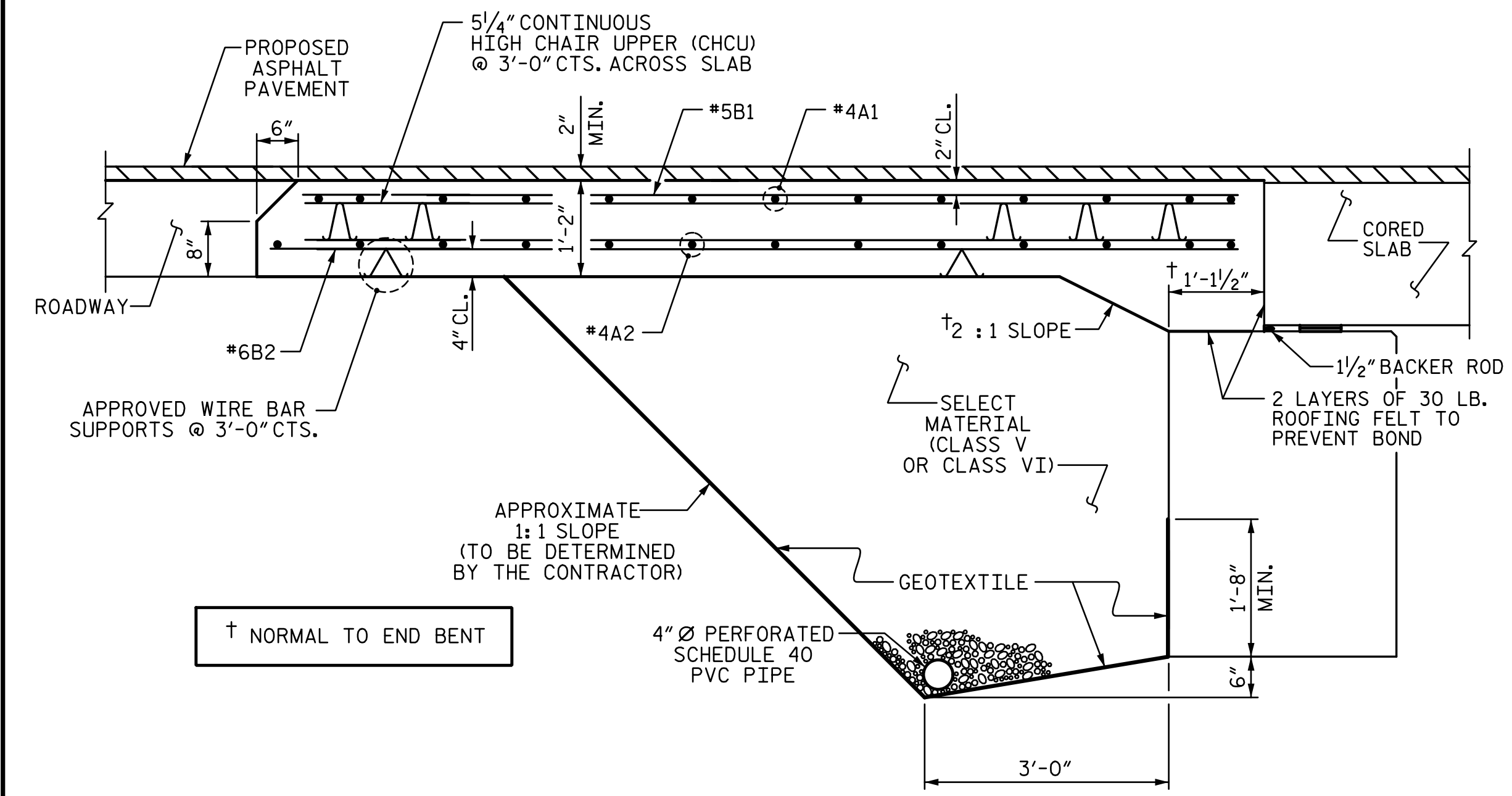
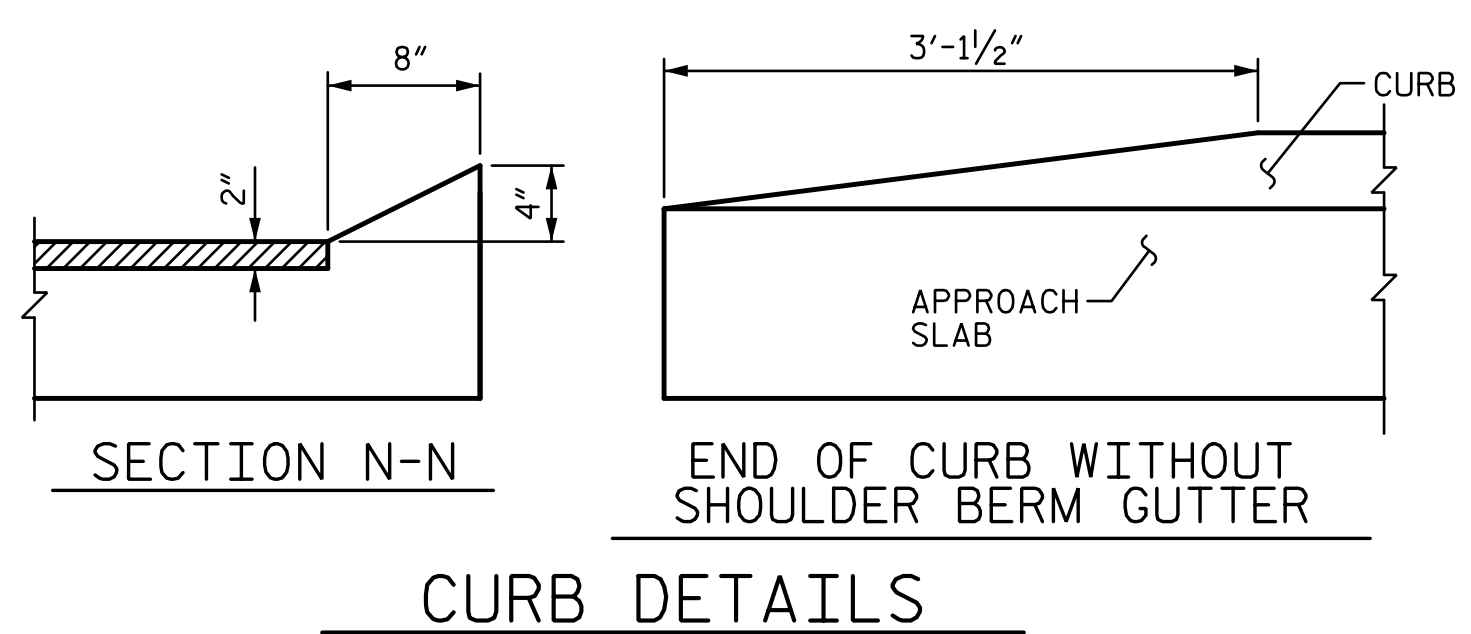

SECTION THRU SLAB
 (TYPE II - MODIFIED APPROACH FILL)

BILL OF MATERIAL

APPROACH SLAB AT EB #1					
BAR	NO.	SIZE	TYPE	LENGTH	WEIGHT
*A1	13	#4	STR	28'-5"	247
A2	13	#4	STR	28'-5"	247
*B1	55	#5	STR	11'-1"	636
B2	55	#6	STR	11'-7"	957
REINFORCING STEEL				LBS.	1204
*EPOXY COATED REINFORCING STEEL				LBS.	883
CLASS AA CONCRETE				C. Y.	17.5

APPROACH SLAB AT EB #2					
BAR	NO.	SIZE	TYPE	LENGTH	WEIGHT
*A1	13	#4	STR	28'-5"	247
A2	13	#4	STR	28'-5"	247
*B1	55	#5	STR	11'-1"	636
B2	55	#6	STR	11'-7"	957
REINFORCING STEEL				LBS.	1204
*EPOXY COATED REINFORCING STEEL				LBS.	883
CLASS AA CONCRETE				C. Y.	17.5

ASSEMBLED BY : CL	DATE : 10-18
CHECKED BY : LEM	DATE : 11-18
DESIGN ENGINEER OF RECORD : LEM	DATE : 12-18
DRAWN BY : SHS/MAA 5-09	REV. 12-17
CHECKED BY : BCH 5-09	MAA/THC

STV 100 YEARS
 STV ENGINEERS, INC.
 900 West Trade St., Suite 715
 Charlotte, NC 28202
 NC License Number F-0991

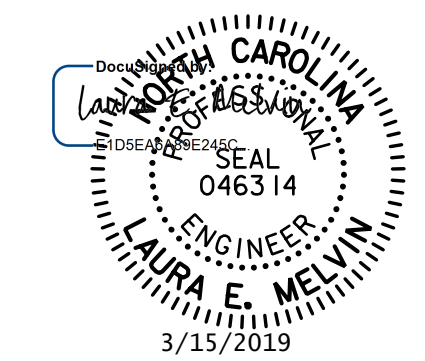

DOCUMENT NOT CONSIDERED FINAL UNLESS ALL SIGNATURES COMPLETED

PROJECT NO. **17BP.10.R.133**
STANLY COUNTY
 STATION: **15+41.00 -L-**

STATE OF NORTH CAROLINA
 DEPARTMENT OF TRANSPORTATION
 RALEIGH
BRIDGE APPROACH SLAB FOR PRESTRESSED CONCRETE CORED SLAB UNIT (SUB-REGIONAL TIER)
 105° SKEW

REVISIONS					SHEET NO.
NO.	BY:	DATE:	NO.	BY:	DATE:
1			3		
2			4		

TOTAL SHEETS: 16